

# NEWS

209/13



ROHDE & SCHWARZ

## New reference source for complex signal scenarios

Today's 4G wireless standards push T&M technology to its limits –  
the new high-end vector signal generator shows what is possible



### Focus

Cost-effective general-purpose measuring instruments can now be conveniently ordered from Rohde & Schwarz webstores

### Broadcasting

High-end test platform for comprehensive testing of audio/video applications

### Broadcasting

Powerful alternative: Solid-state DTV transmitters up to 50 kW succeed IOT transmitters

### Always up to date with the new NEWS app

Tablet users can now read NEWS in digital form. The new NEWS app can be downloaded free of charge from the Google Play Store and the Apple App Store. Initially, only the English version will be available. German, French and Spanish will follow.

The app contains articles from the current print edition plus all articles from the past three years, sorted by topic and accessible within seconds. Videos provide even more information. Graphical symbols indicate which articles have been added since last time the app was used so that the user can quickly find the latest innovation information.



Your benefits:

- Quick access to all articles, sorted by topic
- Timely access to product innovations, no more waiting for the next print edition
- Additional articles that could not be included in the print edition
- Quick access to topic-related content such as application notes, product brochures, videos, etc.

Get the app by searching for "R&S NEWS" or "Rohde&Schwarz" on the app stores, or by scanning one of the QR codes below.



To iPad app



To Android app

## NEWS

Published by Rohde&Schwarz GmbH&Co. KG  
Mühldorfstrasse 15 · 81671 München  
www.rohde-schwarz.com

### Regional contact

- Europe, Africa, Middle East | +49 89 4129 123 45  
customersupport@rohde-schwarz.com
- North America | 1 888 TEST RSA (1 888 837 87 72)  
customer.support@rsa.rohde-schwarz.com
- Latin America | +1 410 910 79 88  
customersupport.la@rohde-schwarz.com
- Asia/Pacific | +65 65 13 04 88  
customersupport.asia@rohde-schwarz.com
- China | +86 800 810 8228/+86 400 650 5896  
customersupport.china@rohde-schwarz.com

Editor and layout: Redaktion Drexl&Knobloch GmbH (German)  
English translation: Dept. GF-MC7  
Photos: Rohde&Schwarz  
Printed in Germany

Volume 53

Circulation (German, English, French, Spanish and Japanese) 75 000  
approx. three times a year

ISSN 0028-9108

Supply free of charge through your nearest

Rohde&Schwarz representative

Reproduction of extracts permitted if source is stated and copy sent  
to Rohde&Schwarz München.

PD 5214.4488.72

R&S® is a registered trademark of Rohde&Schwarz GmbH&Co. KG. Trade names are trademarks of the owners. CDMA2000® is a registered trademark of the Telecommunications Industry Association (TIA-USA). The Bluetooth® word mark and logos are registered trademarks owned by Bluetooth SIG, Inc. and any use of such marks by Rohde&Schwarz is under license. "WiMAX Forum" is a registered trademark of the WiMAX Forum. "WiMAX," the WiMAX Forum logo, "WiMAX Forum Certified," and the WiMAX Forum Certified logo are trademarks of the WiMAX Forum. All other trademarks are the properties of their respective owners.

# Cover feature

Mobile network suppliers and manufacturers of wireless devices demand increasingly powerful measuring instruments that enable them to quickly launch latest technologies and standards such as LTE, LTE-Advanced and WLAN 802.11ac. The required T&M equipment presents a significant challenge for developers. Their task is to combine RF characteristics at the limits of what is feasible with sophisticated radio technologies such as MIMO and



complex data processing for signal calculation, and to ensure that the resulting product is easy to use. The new R&S®SMW200A vector signal generator meets all these requirements. And what's more: As a unique all-in-one instrument, the R&S®SMW200A is able to simulate the entire transmission path between the wireless device and the base station including all relevant effects and in compliance with the applicable standards. A touchscreen, an optimized user interface with very fast setting times and smart soft tools make it extremely easy to use the generator's many functions. For more details, see article on page 6.

# Overview

## NEWS

### 209/13

#### Wireless technologies

#### Signal generation and analysis

■ **R&S®SMW200A**  
**vector signal generator**  
High-end vector signal generator  
creates complex  
multichannel scenarios..... **6**

#### Focus

#### Value instruments

Equipping a lab made easy –  
with value instruments ..... **12**

#### General purpose

#### Oscilloscopes

■ **HMO3000 oscilloscope**  
The new oscilloscope series  
from HAMEG Instruments..... **16**



#### Multimeters

■ **HMC8012 digital multimeter**  
In brief:  
The new HMC compact instrument  
series from HAMEG Instruments ..... **19**

#### Audio/video testers

■ **R&S®UPP audio analyzer**  
Dolby® compliance testing with  
Rohde & Schwarz T&M equipment .... **20**

#### Power measurements

■ **R&S®Power Viewer Mobile app**  
Mobile power measurements using  
a sensor and an Android™ device..... **25**

#### Signal generation and analysis

■ **R&S®SMBV100A**  
**vector signal generator**  
In brief:  
GNSS simulator supports series  
of realistic scenarios ..... **26**

#### R&S®FSH spectrum analyzers

In brief:  
New models up to 13.6 GHz  
and 20 GHz..... **27**



Favorably priced general-purpose measuring instruments from Rohde & Schwarz and its HAMEG subsidiary create a solid basis for any sophisticated electronics lab (page 12).



## EMC / Field strength

### Amplifiers

#### ■ R&S®BBA150 broadband amplifiers

Higher frequencies, more power..... 28



The R&S®BTC broadcast test center is the perfect platform for almost all tests used in the consumer electronics and automotive sectors as well as in professional audio/video applications based on broadcasting standards (page 30).



## Broadcasting

### Signal generation and analysis

#### ■ R&S®BTC broadcast test center

High-end test platform for comprehensive testing of audio/video applications ..... 30

#### ■ R&S®SLG satellite load generator

Multichannel signal generator simulates satellite TV band with full channel load ..... 38

#### ■ R&S®SFC compact modulator and R&S®SFC-U USB compact modulator

In brief ..... 40



### Transmitter systems

#### ■ R&S®THU9 UHF high-power transmitters

Solid-state R&S®THU9 up to 50 kW succeeds DTV IOT transmitters.....41

Optimizing efficiency of high-power TV transmitters..... 44

### Audio/video headends

#### ■ R&S®AVG050 ISDB-T BTS gateway

Compact BTS gateway for ISDB-T<sub>B</sub> networks ..... 48

### Audio/video testers

#### ■ R&S®VTC / VTE / VTS video testers

HDMI 2.0 signal generator for testing 4k consumer electronics equipment..... 50

## Secure communications

### Reference

R&S®Series 4200:  
10 000 ATC radios in 54 countries..... 52

## Miscellaneous

Masthead ..... 2

Newsgrams ..... 54

# High-end vector signal generator creates complex multichannel scenarios



Fig. 1: The new R&S®SMW200A vector signal generator combined with two R&S®SGS100A vector signal generators is by far the most compact solution available on the market today for generating standard-compliant 4x4 MIMO signals for LTE or WLAN test scenarios.

The new R&S®SMW200A high-end vector signal generator with its combination of flexibility, top performance and intuitive operation surpasses all comparable solutions available on the market today. It generates high-quality, complex, digitally modulated signals. Highly configurable, it can be used in applications ranging from a single-path vector signal generator to a multichannel MIMO receiver tester.



The app version of this article contains a video that describes the new generator in more detail.

### Keeping pace with increasing complexity

The demand for increasingly powerful communications networks continues. That's why modern wireless standards use transmission channels with large bandwidths, such as LTE with up to 20 MHz and the WLAN standard IEEE 802.11ac with up to 160 MHz. Spectral efficiency improves with increasingly higher MIMO modes, e.g. wireless LAN with up to 3x3 and LTE with up to 4x4 or 8x2. LTE-Advanced and IEEE 802.11ac can also simultaneously transmit on multiple carriers.

Network providers must integrate this multiplicity of new technologies as efficiently as possible into existing infrastructures, which is why 2G, 3G and 4G networks coexist. Correspondingly complex is the design of the transmitters and receivers in multistandard base stations and wireless devices. The T&M equipment and the test scenarios used must satisfy the most stringent requirements.

Signal generators in this environment must provide a full range of complex, high-quality test signals, yet be easy to operate. The new R&S®SMW200A vector signal generator (Fig. 1), with its unique concept, is tailored to these requirements.

### Easy generation of complex signals

The R&S®SMW200A generates signals in the frequency range from 100 kHz to 3 GHz or 6 GHz. With its powerful and flexible baseband section and an I/Q modulation bandwidth of 160 MHz (in RF) with internal baseband, it is the ideal vector signal generator for developing wideband communications systems and verifying 3G and 4G base stations. It supports all major mobile and wireless connectivity standards via software options that can be used to configure and generate the signals directly on the device.

Fig. 2: A single R&S®SMW200A with two paths can generate a wanted signal and an interference signal. In this example, an LTE and a 3GPP FDD signal are added in the baseband (with frequency offset) and output on the RF path A. If needed, RF path B can be used for an additional CW interferer.

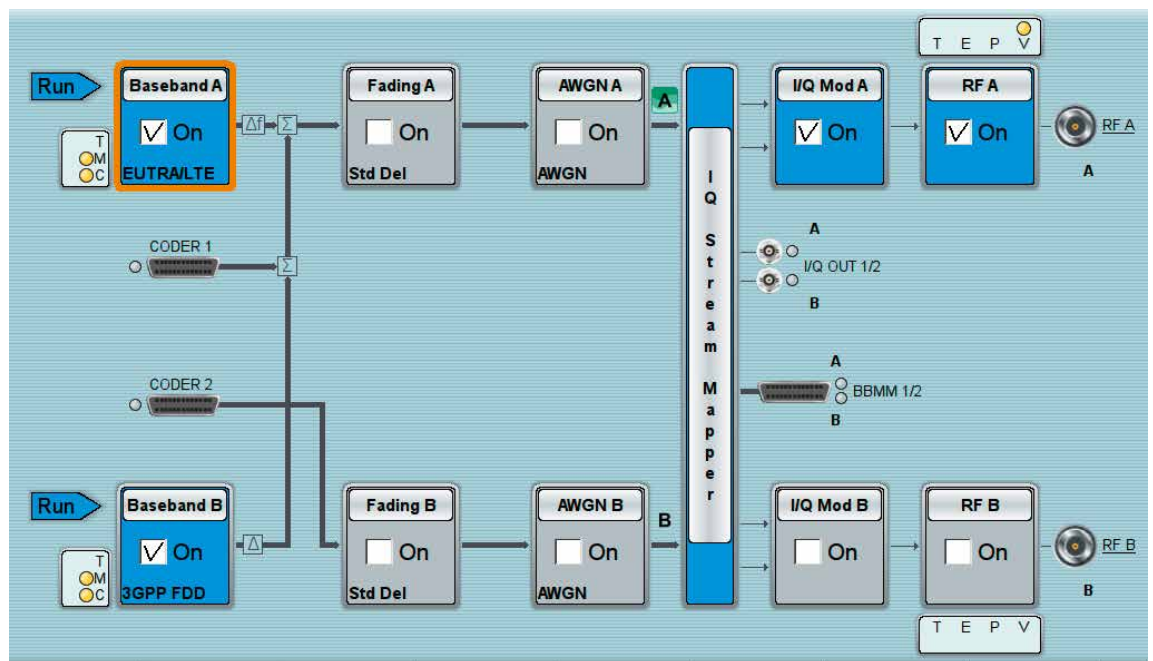

Thanks to its modular design, the generator can be equipped with the exact options required for a specific application. Any configuration is possible – from a classic single-path vector signal generator to a multichannel MIMO receiver tester.

The R&S®SMW200A can be equipped with up to two internal baseband modules, four fading simulator modules and two RF paths, which results in two full-scale vector signal generators in a single box. Signals can be digitally added internally – also with frequency, level and phase offsets. This allows a single R&S®SMW200A to generate complex signal scenarios that usually require several generators, e.g. for dual cell, TX/RX diversity, or signal and interference scenarios that are often required for receiver tests (Fig. 2).

The baseband section of the generator can provide up to eight signal sources and up to 16 logical faders. This makes the R&S®SMW200A ideal for higher-order MIMO scenarios and multi-user scenarios – test scenarios that previously could not be realized at all or required multiple generators. With a maximum fading bandwidth of 160 MHz, the R&S®SMW200A also covers the latest standards such as WLAN IEEE 802.11ac.

A single R&S®SMW200A can, for example, generate signals for 8x2 MIMO as required by TD-LTE with very little effort. Because no other generators

besides the R&S®SMW200A are needed, no time-consuming cabling, calibration and synchronization of multiple devices is required. Sophisticated operating aids help the user make the necessary settings. The global system-configuration dialog is used to modify the block diagram for an 8x2 signal scenario (Fig. 3). The signals of the eight transmitter antennas can be configured quickly and easily in a shared menu. The matching MIMO fading scenario is also quickly configured since the generator provides predefined settings for all major standards.

All important signal parameters can be set individually to create special test scenarios. The user can quickly set up the needed scenario without sacrificing flexibility.

For applications with more than two RF paths, the setup can be expanded with external I/Q-modulated R&S®SGS100A vector signal generators \* (Figs. 1 and 4). These are controlled via USB or LAN directly from the R&S®SMW200A and are seamlessly integrated into its user interface. A single R&S®SMW200A and two R&S®SGS100A provide a compact 4x4 MIMO solution in just five height units.

Its multipath approach makes the R&S®SMW200A ideal for generating signals in multicarrier and multi-user scenarios, even and especially in combination with MIMO. As can be seen in Fig. 5, the

\* R&S®SGS100A – the smallest fully integrated vector signal generator for automatic test systems. Briefly described in NEWS 204/11, p. 38.

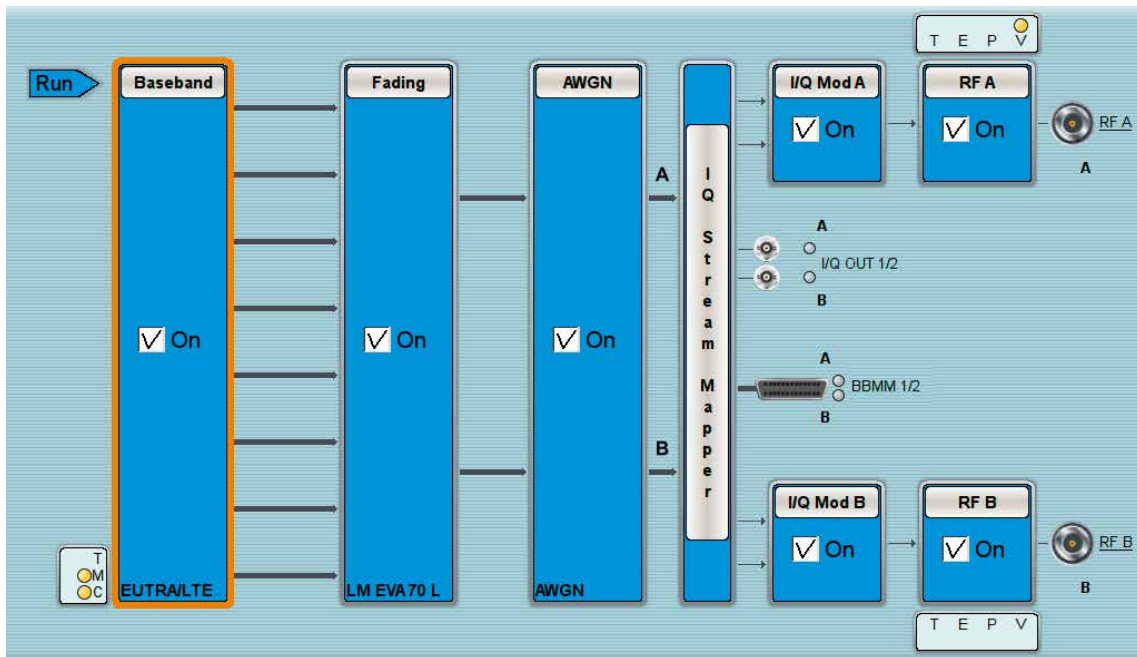
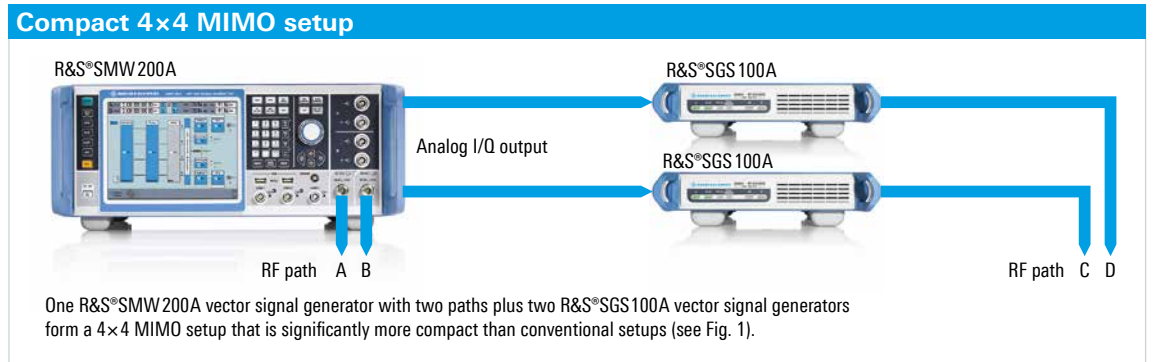

Fig. 3: Block diagram for 8x2 MIMO. A single R&S®SMW200A generates the complete signal scenario, including fading and AWGN, here for TD-LTE.



Fig. 4: The two R&S®SGS100A generators provide RF paths 3 and 4 and are operated from the R&S®SMW200A. The baseband signal and fading are generated entirely by the R&S®SMW200A.



WLAN 802.11ac (1 x 3 x 3)

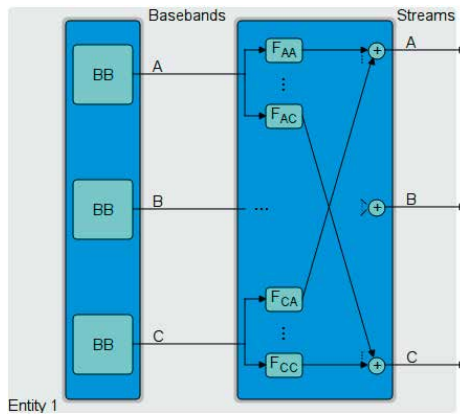

WCDMA type 3i (1 x 3 x 2)

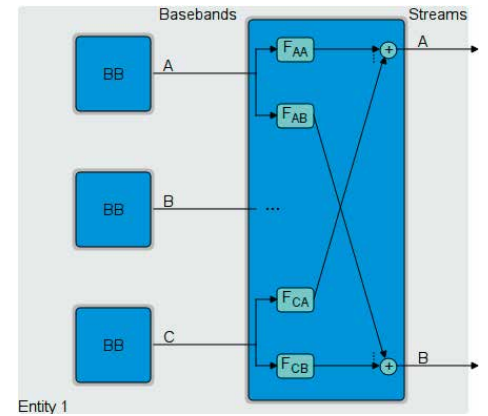

Dual carrier / dual band HSPA (2 x 2 x 2)

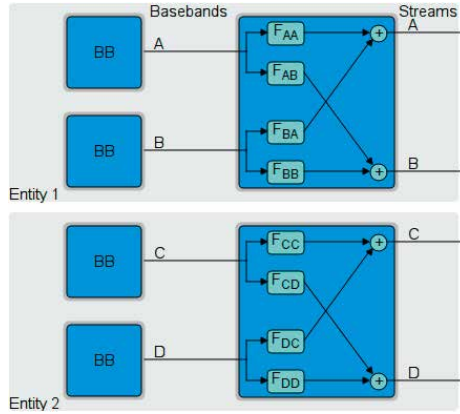

LTE-A CA with 2x2 MIMO (2 x 2 x 2)

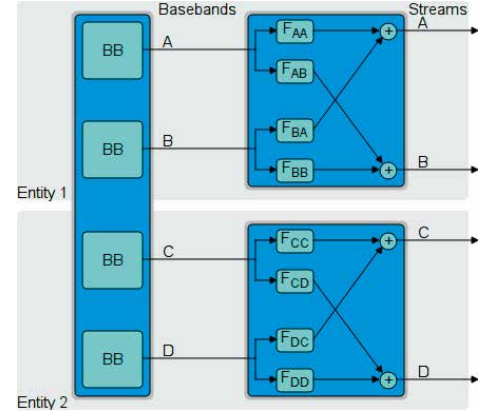

LTE 4x4 MIMO (1 x 4 x 4)

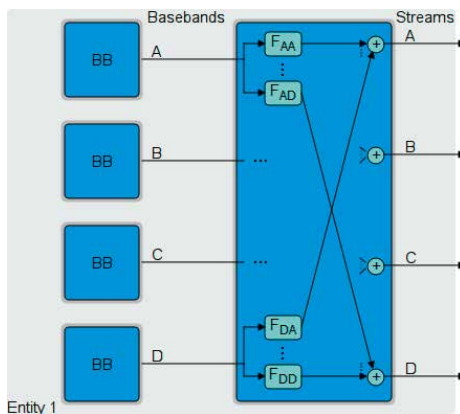

LTE 8x2 MIMO UE test (1 x 8 x 2)

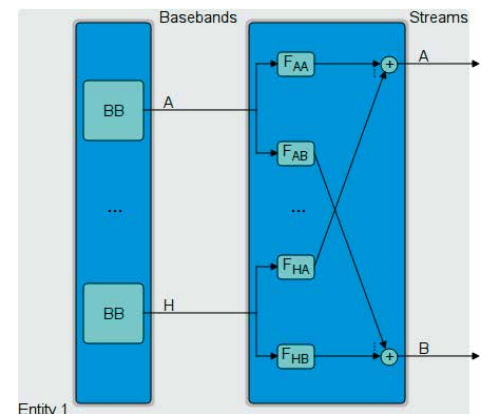

Fig. 5: Generating signals for complex scenarios is the core competency of the R&S®SMW200A. Here are some examples.

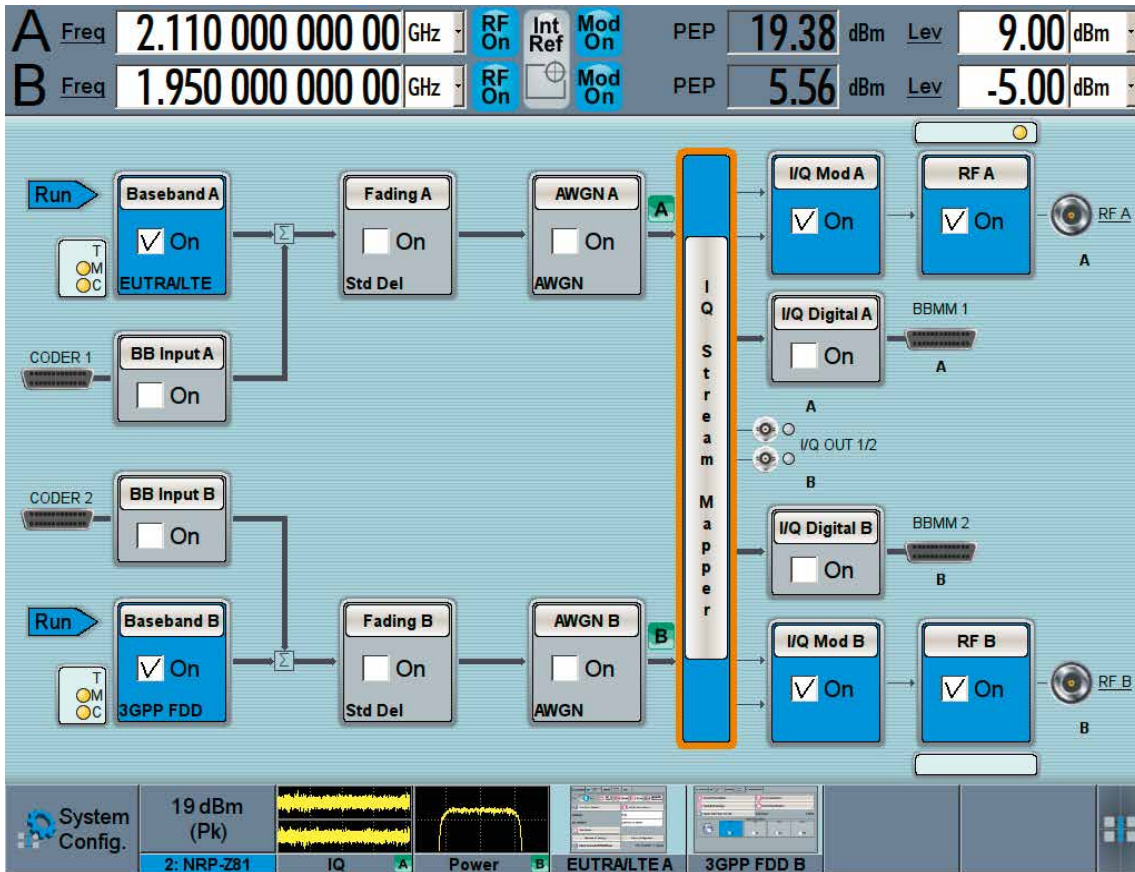

Fig. 6: User interface of the R&S®SMW200A. The header shows frequency, level and important device states. The footer provides quick access to open menus. The generated signals and the measurement results of any connected R&S®NRP-Zxx power sensors can also be displayed.

R&S®SMW200A easily masters challenges such as LTE-Advanced carrier aggregation with 2x2 MIMO or dual cell HSPA.

### Convenient operation reduces development times

An intuitive operating concept was one of the priorities when developing the R&S®SMW200A. Numerous user guidance innovations facilitate working with complex signal scenarios. A high-resolution touchscreen and an easy-to-use graphical user interface provide ergonomic operation. A block diagram representing the current signal scenario ensures a clear overview at all times and the signal flow is visible at a glance (Fig. 6).

The built-in graphics function allows the generated signals to be displayed in realtime – an extremely useful tool, especially for complex signals (Fig. 7).

The user can select the type of display (spectrum, I and Q versus time, CCDF, etc.) and the point in the signal flow where the measurement will be performed (e. g. before or after the fading section).

All signal parameters can be set on the user interface. Separate PC software is not required. Numerous predefined settings and test models for the different standards as well as test case wizards for 3GPP FDD and LTE base station conformance tests let users work in a fast and targeted manner.

The context-sensitive help system provides information for every parameter, such as the setting range, a detailed functional description and the corresponding SCPI command. Functions such as “Mark all changes with respect to Preset” or the individual resetting of individual parameters facilitate daily work.

Fig. 7: The integrated graphics function displays the generated signals in realtime.

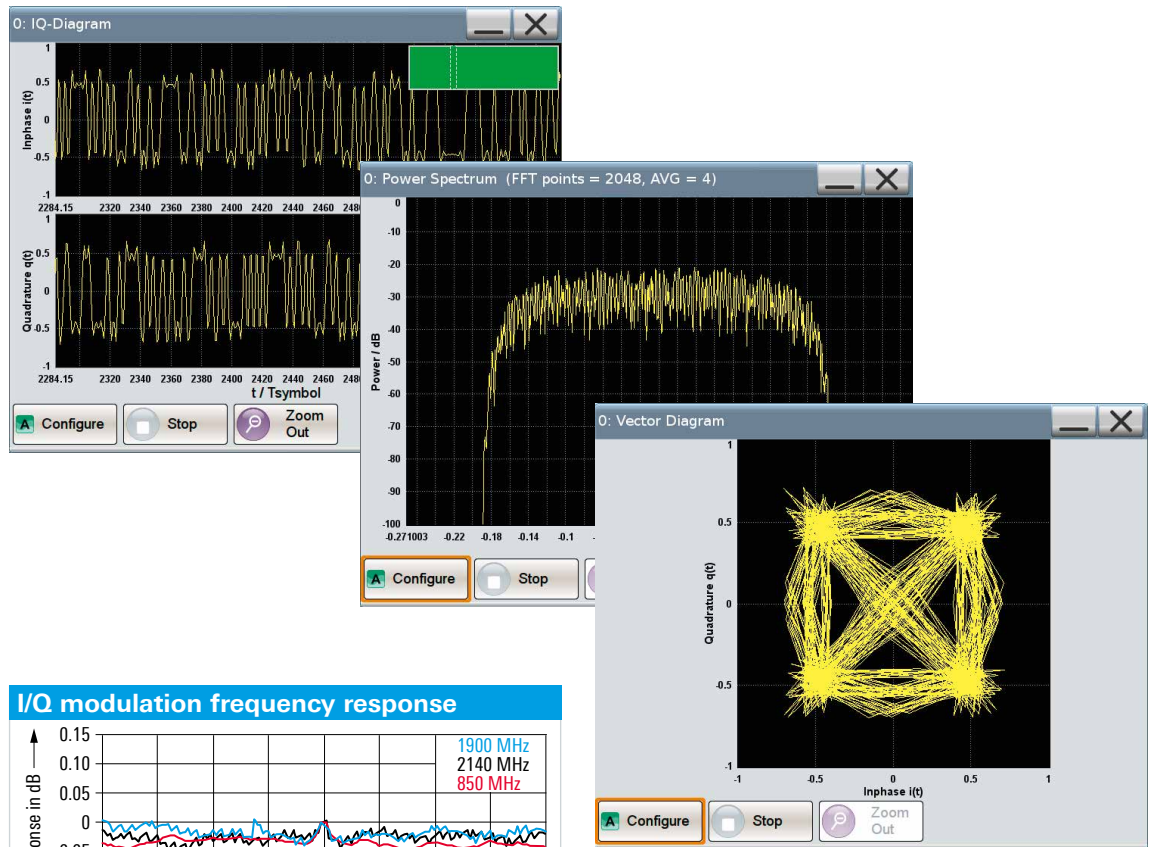
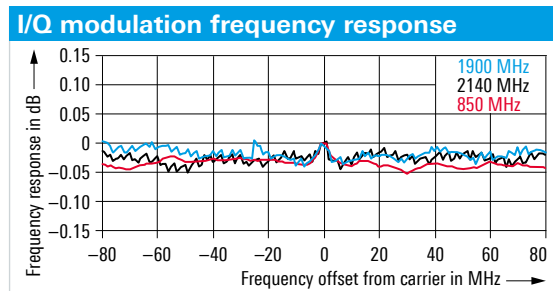

Fig. 8: The measured I/Q modulation frequency response with internal baseband.



### Excellent signal quality – a prerequisite for high-quality products

Product quality is a key differentiating factor in this fiercely competitive business. The R&S®SMW200A delivers the excellent signal quality needed to develop high-quality RF and baseband modules. Equipped with the R&S®SMW-B22 option, the generator achieves typical SSB phase noise values of  $-139$  dBc at 1 GHz carrier frequency and 20 kHz offset. The ACLR of a signal for 3GPP Test Model 1 with 64 DPCH is  $> 70$  dB (1.8 GHz to 2.2 GHz carrier frequency, 5 MHz offset).

State-of-the-art 16-bit D/A converters and an excellent RF chain ensure outstanding modulation characteristics. The I/Q modulation frequency response achieves measured values of around  $\pm 0.05$  dB over 160 MHz bandwidth (Fig. 8). The R&S®SMW200A generates 160 MHz wide WLAN IEEE 802.11ac signals with an EVM of  $-49$  dB (typ.).

### Summary

The R&S®SMW200A combines the functions of several devices into a single signal generator and significantly simplifies the complex measurement tasks increasingly found in today's 3G and 4G wireless standards. Its scalable platform allows users to customize the generator to their applications and to expand it at any time when new challenges arise, making it a secure investment for the future. The intuitive operating concept helps users complete tasks faster, no matter how complex their measurements may be. All in all, the R&S®SMW200A is the ideal tool for developing high-quality products both quickly and efficiently.

Dr. René Desquozet; Simon Ache

# Equipping a lab made easy – with



Rohde & Schwarz is primarily known for its T&M equipment at the top end of the performance scale. Yet the Rohde & Schwarz program has long included cost-effective general purpose measuring instruments as well. These and products from HAMEG, a Rohde & Schwarz subsidiary, can now be conveniently ordered from Rohde & Schwarz webstores.

Fig. 1: A powerful offer: Favorably priced general purpose measuring instruments from Rohde & Schwarz and its HAMEG subsidiary create a solid basis for any sophisticated electronics lab.



# value instruments

## All that is needed to meet basic requirements

Everyday lab work does not always involve highly complex measurements or technical frameworks that require high-end T&M instruments. For basic lab tasks, flexible and cost-efficient workhorses are needed on the lab bench – uncomplicated, yet versatile and highly reliable tools such as oscilloscopes, multimeters, frequency counters, power supplies, generators and analyzers (Fig. 1). It should be as easy to purchase and service these instruments as it is to use them. Rohde&Schwarz has selected suitable products from its own portfolio and combined them with the HAMEG product range in an attractive Value Instruments Catalog (Fig. 2). In many countries, the instruments can be ordered through the company's own webstores, reducing the effort of setting up a high-quality electronics lab to one-stop online shopping (Fig. 4).



Fig. 2: The Value Instruments Catalog is available from any Rohde&Schwarz representative or can be downloaded from [www.rohde-schwarz.com/value](http://www.rohde-schwarz.com/value).



### Best quality even in the lower price segment

In addition to ease of use and superior quality, all value instruments boast an excellent price/performance ratio. Many of the instruments offer unique features that make everyday lab work much easier. R&S®RTM oscilloscopes\*, for example, are ready to start measuring right after being switched on, and display all key signal parameters at a glance thanks to the QuickMeas function. The new HAMEG HMC8012 digital multimeters (page 19) offer a four times higher measurement range than other multimeters in their class – without requiring range switching. They also permit current measurements across the entire range with only one connector – a major plus for operating safety and handling.

Rohde&Schwarz stands for high measurement precision and performance across all product categories. The same applies to manufacturing quality: Value instruments are subject to the same strict quality standards and produced in the same plants as high-priced Rohde&Schwarz products (Fig 3). As a result, they meet the highest requirements with respect to material and manufacturing quality.

### Quality T&M equipment for everyone

The value instruments portfolio addresses not only large corporations, but also users in medium and small-sized companies who in the past found Rohde&Schwarz products too expensive. Thanks to easy procurement and favorable purchase prices, quality T&M equipment is now available to all professional users. High productivity, longevity and reliability make value instruments a profitable investment.

Volker Bach

\* The new R&S®RTM2000: switch on, measure, done. NEWS (2013) No. 208, pp. 30–33.

Fig. 3: The Rohde&Schwarz plant in Vimperk, Czech Republic, produces both HAMEG products and many Rohde&Schwarz instruments. The plant has a high manufacturing depth and covers the complete value added chain, from metal processing and cable and wire wrap part production to assembly and surface treatment. As a result, Rohde&Schwarz is in control of all factors determining the quality of the final product.



**ROHDE & SCHWARZ**

Welcome to the R&S Webstores

If you know what you need, you can order high-performance instruments cost-efficiently in our WebStore.

Please choose the WebStore of your country and check it out

If there is no webstore available in your country please contact your local sales representative or have a look at our list of national websites.

North America	Europe	Middle East and Africa
United States of America	Austria	Algeria
	Bulgaria	Angola
	Czech Republic	Bahrain
	Denmark	Benin
	Finland	Botswana
	Germany	Burkina Faso
	Hungary	Burundi
	Italy	Cameroon
	Norway	Cape Verde
	Poland	Central African Republic
	Romania	Chad
	Slovakia	Congo - Brazzaville
	Slovenia	Congo - Kinshasa
	Spain	Côte d'Ivoire
	Sweden	Djibouti
	United Kingdom	Egypt
		Madagascar
		Malawi
		Mali
		Mauritania
		Mauritius
		Morocco
		Mozambique
		Namibia
		Niger
		Nigeria
		Oman
		Palestinian Territories
		Qatar
		Rwanda
		Réunion
		Saudi Arabia
		Tanzania



## HAMEG Instruments

HAMEG Instruments, a German company founded in 1957, develops electronic standard measuring instruments in the lower price segment for use in development labs, production testing, service and education. The company became a member of the Rohde&Schwarz group in 2005. HAMEG instruments are developed at company headquarters in Mainhausen near Frankfurt and in Chemnitz. They are manufactured at the Rohde&Schwarz plant in Vimperk (Czech Republic, near the German border), just like many standard T&M instruments from Rohde&Schwarz. They are subject to the same strict quality standards as higher-priced products. HAMEG products are available via numerous distributors or can be ordered directly from the Rohde&Schwarz sales organization and the Rohde&Schwarz webstores.

**ROHDE & SCHWARZ**

English

0 article

New equipment Ex demo-equipment How to buy About Rohde & Schwarz UK HAMEG Summer Specials 2013

Enter search keyword Go Business area: Login or register

**Product range**

- Oscilloscopes
- Power Meters
- Signal & Spectrum Analysis
- Signal Generation
- Network Analysis
- EMC & Field Strength Test Solutions
- Broadcasting T&M
- Power Supplies
- HAMEG Programmable Instruments
- HAMEG Modular Series

**HMO Scope + HMS spectrum analyzer = 10% discount**

Welcome to our webstore!

For any questions please do not hesitate to contact us, we will be glad to give you all the assistance you need. Currently we can only deliver to EU countries. All prices in the webstore are shown without taxes. VAT will be shown in the shopping cart.

Please login to get an online quotation or to see your individual prices.

Featured Products

Fig. 4: In many countries, value instruments can be ordered from a Rohde&Schwarz webstore. Visit [webstore.rohde-schwarz.com](http://webstore.rohde-schwarz.com) to check if you can take advantage of this opportunity. The instruments can of course still be ordered through the usual sales channels.



Since 2012, the HAMEG product logo has indicated that the company is part of the Rohde&Schwarz group of companies.

# HMO 3000: the new oscilloscope series from HAMEG Instruments

The six new mixed-signal oscilloscopes in this series are available in bandwidths ranging from 300 MHz to 500 MHz and with either two or four channels. They offer many powerful features and – in typical HAMEG fashion – are available at an attractive price.

## HAMEG: performance at an attractive price

Today's development designs, which feature mixed analog and digital circuits and integrated bus systems, set the pace for developers, giving them less and less time to prepare their complex products for market maturity. Analyzing the signal slopes to be characterized during this process

requires sufficient bandwidth and appropriate sampling rates. HAMEG Instruments meets these requirements by introducing the new HMO3000 series of mixed-signal oscilloscopes (Fig. 1). The two- and four-channel instruments provide bandwidths of 300 MHz, 400 MHz and 500 MHz, a sampling

Fig. 1: The two- and four-channel HMO3000 instruments provide bandwidths of 300 MHz, 400 MHz and 500 MHz, a sampling rate of 4 Gsample/s and a memory depth of eight million points.

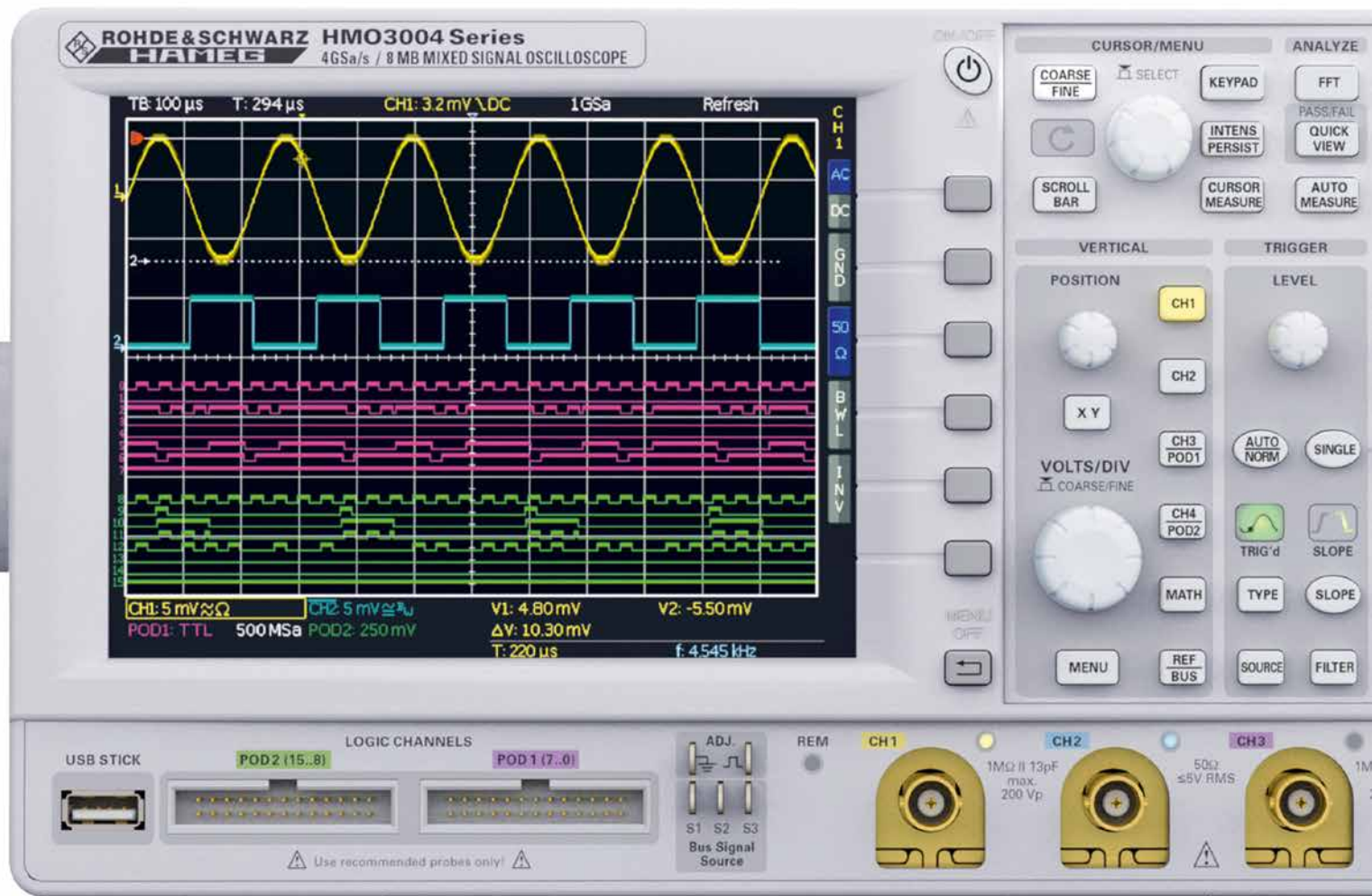





The app version of this article includes a video that presents the features of the new oscilloscopes in detail.

rate of 4 Gsample/s and a memory depth of eight million points. HAMEG is offering the new HMO3000 instruments as mixed-signal oscilloscopes throughout, i.e. they can be used for investigating analog and digital signals simultaneously. The HO3508 / HO3516 low-capacitance logic probes (100 k $\Omega$  || 4 pF) are optional. They allow the analysis of up to 16 logic channels at a sampling rate of 1 Gsample/s.

The 300 MHz and 400 MHz models can be enhanced at any time to the 500 MHz maximum bandwidth by means of a simple software upgrade.

### Analysis functions for serial buses

Same as all other HAMEG digital oscilloscopes, the new HMO oscilloscopes can also analyze serial buses – i.e. trigger and decode serial data streams – by using the HOO10 and HOO12 options. The HOO10 option covers the I<sup>2</sup>C, SPI and UART/RS-232 protocols, while the HOO12 option allows the analysis of the CAN and LIN protocol. Either option can be used to analyze both analog and digital channels. Users are able to test the options: Both come factory-installed with 20 hours of free instrument run-time and can be enabled at any time.

The analog channels should be used where the emphasis is on analyzing the signal quality of a serial bus. Fig. 2 shows as an example an I<sup>2</sup>C data stream on analog channels.

The digital channels should be used if two serial buses are to be analyzed simultaneously. Digital channels also offer advantages where the events on a serial bus are triggered by voltage sequences on analog channels. Fig. 3 illustrates the time correlation between a switching operation on an analog channel and the I<sup>2</sup>C data consequently sent on the digital channels.

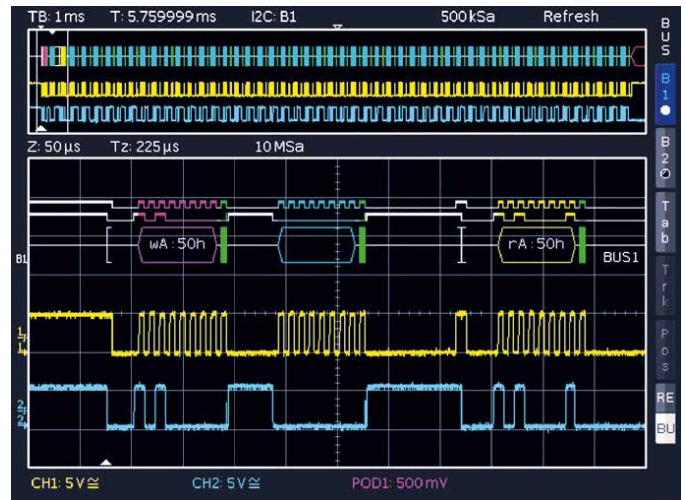

Fig. 2: Analysis of an I<sup>2</sup>C data stream on analog channels.

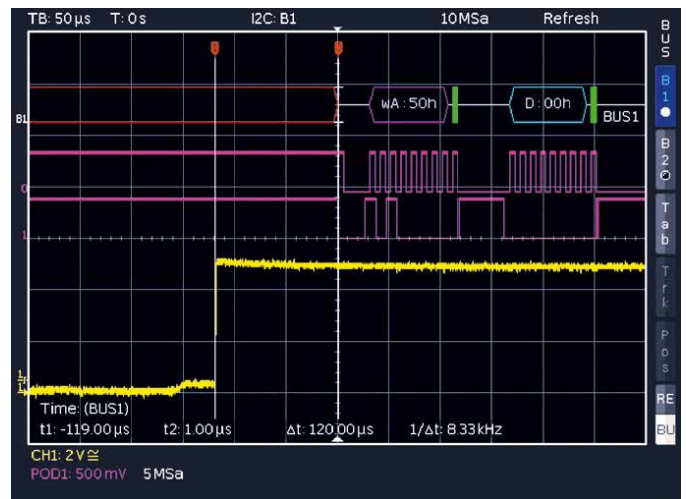

Fig. 3: Time correlation of a switching operation on an analog channel (bottom) and I<sup>2</sup>C data consequently transmitted on the digital channels (top). (Based on example in Fig. 2).

### Segmented memory

The HMO3000 series is the first generation of HAMEG oscilloscopes that allow users to segment the available memory. As of the fourth quarter of 2013, this function will be available as an option (HOO14). Segmented memory is memory that is divided into multiple blocks. The maximum block size depends on the total number of blocks. Segmenting memory may be useful, for instance, if there are large gaps between individual data packets during serial bus communications. In this case, the user can segment the memory so that a separate memory block exists for each expected data packet. The blocks are then filled with data based on the current trigger settings. Periods between packets without data are not recorded, which in



turn allows the user to record significantly more information. It is also possible to record specific events during long-term tests multiple times, which allows the user to identify accumulations or patterns of these events more easily.

Another example that highlights the advantages of a segmented memory is the ability to capture sporadic anomalies during many short events that occur in quick succession. Segmenting the memory into an appropriate number of blocks allows the instrument to record many short events in a single stretch. Subsequently, the blocks can be scanned for anomalies. Search functions are available for this purpose.

Like all software options that can be enabled in the HMO3000 series, the segmented memory option will come with 20 hours of free runtime to allow thorough testing by users.

### TRIGGER OUT and interfaces

Another new feature for HAMEG oscilloscopes is the TRIGGER OUT output on the back panel of the HMO3000 instruments. This output is required, for instance, for recording address and data signals over an extended period of time before or after a specific trigger event in the oscilloscope. A data logger at the trigger output is used for this purpose.

The HMO3000 oscilloscope series comes with a new data interface integrated as standard. Previous instruments had a combined serial and USB interface (HO720), while the new series is equipped with a combined Ethernet and USB interface (HO730). In the future, the serial / USB interface will be available as an option, as will the GPIB interface (HO740).

### Integrated bus signal source ...

The bus signal source integrated with all HAMEG HMO instruments remains unique among mixed-signal oscilloscopes. Here, three outputs were added to the standard probe adjust oscillator. At these outputs, an internal circuit provides randomly generated serial data for the various protocols (I<sup>2</sup>C, SPI, UART) or alternatively a random 4-bit pattern or a 4-bit counter signal, depending on requirements. This solves one of the most common problems during bus analysis, namely incorrect setup. Users can now verify the settings for circuit analysis using known signals.

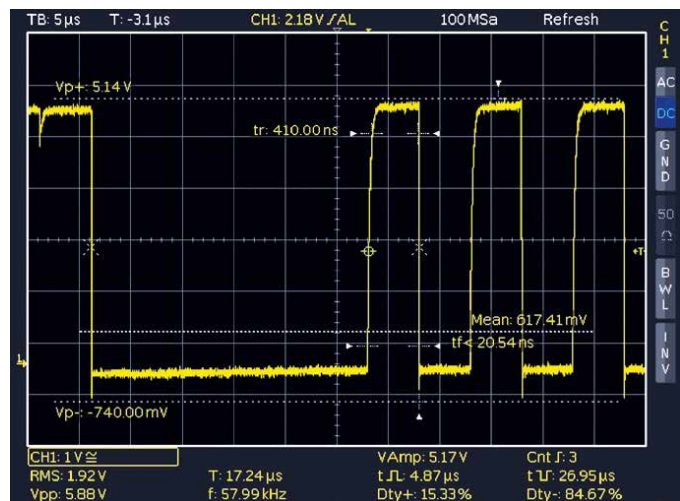

Fig. 4: QuickView values are continuously updated in HMO3000 oscilloscopes.

### ... and many other interesting features

The fan in the new oscilloscope series is fully integrated into the solid metal casing. This has made it possible to reduce noise levels to the extent that the active cooling of the oscilloscope is barely perceptible, even while listening closely in a quiet environment.

Despite internal mechanical modifications, the compact design has remained unchanged for the new oscilloscopes. Other features carried over from the predecessor models are the 6-digit hardware counter, the outstanding FFT function with a memory depth of 64,000 points, the extensive mathematics functions, the comprehensive auto measurement options and the convenient QuickView function (Fig. 4). Another aspect unique in this instrument class is the vertical input sensitivity which scales as low as 1 mV/div. Although the instruments come with comprehensive online help, HAMEG continues to include a printed manual.

Kai Scharmann

This article is an abridged version of the article published in German technical journal "Elektronik", issue 13/2013.

# In brief

## New HMC compact instrument series from HAMEG Instruments

The new HMC compact instrument series is being introduced to the market by HAMEG Instruments in a space-saving half-19" format. All instruments in the series will be LXI certified and support the USB TMC class as well as the virtual COM port (VCP) to communicate via the USB interface. Models with permanently installed GBIP interface are also available.

The HMC8012 digital multimeter is starting off the new series. In contrast to the standard 5½ digit display usual in this class, it offers a 5¾ digit display, respectively 480,000 points, resulting in a measurement range that is four times higher without requiring range switching. It allows measurements in measurement category II with a voltage of up to 600 V; only 300 V are standard in this instrument class. With the HMC8012, current measurements across the entire range can be performed using only one connector. Additionally, an integrated wattmeter enables power measurements in the DC range.

With a basic measurement uncertainty of 0.015 % in the DC range, the multimeter shows up to three measured quantities simultaneously on its TFT color display. Altogether

it offers 12 measurement functions:  $V_{DC}$  and  $I_{DC}$ , true RMS  $V_{AC}$  and  $I_{AC}$ , frequency, two- and four-wire resistance, capacitance, continuity, diode, temperature and power. Extensive mathematics functions such as limit testing, min/max, mean value, offset, DC power, plus dB and dBm level round out the range of functions. The instrument provides true RMS measurements in the AC and DC ranges, which is a highly useful feature. Up to 200 measurements per second are possible, depending on the selected range.

All instruments in the HMC series will be LXI certified. They provide LXI core functionality, so users may access a web server to set up the instrument via a LAN interface. Interchangeable virtual instrument (IVI) drivers are another important requirement for obtaining LXI certification. For the HMC series,

HAMEG provides IVI.NET drivers based on Microsoft .NET framework version 4. Traditional LabVIEW and LabWindows™/CVI drivers will also be available for the new series.

In addition to a LAN interface, all HMC instruments include a USB device port. For this interface, users can select if the instrument is accessed via a virtual COM port (VCP) or via USB TMC class. All HMC instruments are optionally available with a built-in GPIB interface.

All products in the HMC series are CSA certified and can be ordered with calibration documents from the factory.

For more information, see <http://www.hameg.com/716.0.html>

In contrast to the standard 5½ digit display usual in this class, the HMC8012 digital multimeter offers a 5¾ digit display, respectively 480,000 points, resulting in a measurement range that is four times higher without requiring range switching.



# Dolby® compliance testing with

Audio analyzers and test software from Rohde & Schwarz enable Dolby® licensees to subject their new products to the required, comprehensive compliance tests before they are launched on the market. The software saves considerable time and automatically generates a test report that merely needs to be sent to Dolby® Laboratories.



Fig. 1: The R&S®UPP audio analyzer and the new test program make Dolby compliance testing fast, convenient and error-free. In this example, the R&S®SFC compact modulator modulates the Dolby test data streams onto the RF carrier.

# Rohde & Schwarz T&M equipment

## Rohde & Schwarz is a test partner of Dolby® Laboratories

Dolby® Laboratories, Inc.\*, headquartered in San Francisco, California, USA, was founded in 1965 by Ray Dolby. The company quickly made a name for itself with noise reduction methods for analog audio equipment. It now specializes in digital multichannel sound formats. Dolby® technologies have become an integral part of audio applications in broadcasting, cinema and home entertainment. For example, Dolby Digital® is an audio coding/decoding technology that provides up to 5.1 discrete audio channels for all types of surround sound applications. Dolby Digital Plus® further optimized audio coding technology, expanding it to 7.1 channels.

\* Dolby®, Dolby Digital® and Dolby Digital Plus® are registered trademarks of Dolby Laboratories, Inc.



## Test requirements defined by Dolby

Different Dolby technologies are used, depending on the device type and the application. The test requirements also depend on the device under test (DUT) – TV sets and A/V receivers require different tests. For each application, Dolby has created packages that help developers to integrate Dolby technologies into audio devices. These packages, called system development kits (SDK), also contain all test instructions. All Dolby tests follow the same basic scheme (Fig. 2):

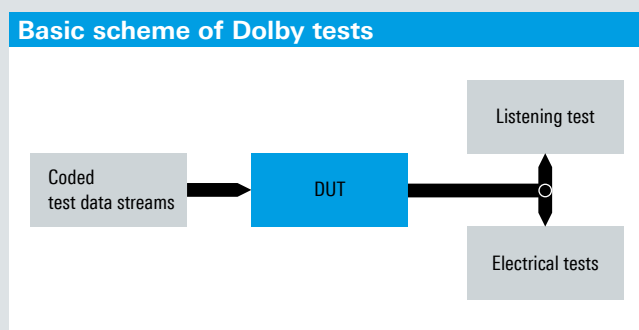

Fig. 2: Basic configuration for Dolby tests.

- The coded test data streams provided by the Dolby SDK are fed to the DUT.
- The DUT processes the data streams and outputs them as decoded audio signals over its various interfaces.
- Electrical tests are used to determine device characteristics and quality parameters such as level stability, distortion, etc.
- In addition, listening tests are defined in which, for example, channel assignment is checked. There are also tests that determine to what extent a DUT is able to compensate defined transmission errors such that they cannot be heard.

Today's consumer electronics equipment offers a wide range of interfaces. Dolby has defined tests for all these interfaces – for example, for analog outputs (loudspeaker or headphone outputs, line out) as well as for digital interfaces in line with the S/P-DIF or HDMI™ standard. In addition, Dolby has defined Internet-enabled tests, in which test data streams are read from an external hard disk into a TV set and decoded there.

The use of Dolby technologies is permitted only when licensed by Dolby Laboratories. Every new device must pass a compliance test in line with Dolby Laboratories specifications before it is put on the market. This requirement ensures that the implemented technology, e.g. in a TV set, functions exactly as defined by Dolby. To make work easier for licensees when developing new devices, Dolby provides defined test signals and detailed test instructions for compliance tests. These tests are quite extensive and place some demands on the user, since they require close attention to numerous conditions and their interdependencies. Although made easier by predefined device settings, the tests can take several hours, depending on the DUT, and must be performed exactly in line with the instructions. Up to now, test results and graphs had to be manually entered into documents specified by Dolby.

The R&S®UPP audio analyzer (Fig. 1) and the new test program from Rohde & Schwarz not only make all these tasks considerably easier and more convenient to perform, they also ensure that no errors occur. The program prompts users to enter the configuration settings and, based on these settings, automatically selects the suitable subtests. Under program control, the test signals are played and the measurements performed. While the individual steps are being carried out, a test report is automatically generated and only needs to be sent to Dolby Laboratories.

## Fast and error-free – the Rohde & Schwarz solution

The first test program Rohde & Schwarz implemented is the one for the Dolby software development kit (SDK) called "Dolby Digital Plus® Decoder for Consumer Broadcast Products"; the program is used as an example in the following description. This SDK is designed for TV sets and set-top boxes that use Dolby Digital® and/or Dolby Digital Plus®. The test sequence is controlled by the R&S®UPP audio analyzer's built-in computer. Fig. 3 shows a typical test setup for TV sets.

In this example, the R&S®SFC compact modulator (see page 40) modulates the Dolby test data streams onto the RF carrier. The streams are fed to the antenna input of the DUT, which demodulates the RF signal and decodes the audio signals.

The R&S®UPP can perform measurements on analog outputs (line out, loudspeakers or headphones) and on the S/P-DIF and HDMI™ audio return channel (ARC) digital interfaces. If the DUT has output lines for coded audio signals (S/P-DIF or HDMI™ with compressed signals in line with IEC 61937), these signals can be decoded for the measurement directly on the R&S®UPP.

Listening tests are also supported. For this purpose, the loudspeakers are connected to the TV set via an A/V receiver.

The heart of the test setup is the R&S®UPP audio analyzer. Its test program guides the user through the entire sequence, and the built-in computer executes the Dolby test program. It is best to use the R&S®UPP800 with eight channels, because this model can handle all possible interfaces and can measure all analog channels in parallel even with 7.1 applications (Dolby Digital Plus®). The analyzer needs to be equipped with the options for measurements on digital interfaces.

The R&S®SFC compact modulator is used to generate RF antenna signals. Since TV standards are different in Europe and the USA, for example, the R&S®SFC must be equipped with the appropriate coder options.

The actual test is preceded by a configuration section in which the user is prompted to enter information e.g. about the manufacturer, the type and the model designation of the DUT. Entering the correct information about the DUT's inputs and outputs is crucial to the test sequence, for the individual test steps are defined on the basis of this information (Fig. 4). Since the test program adapts all measurements to the specific DUT in accordance with the relevant guidelines, test engineers do not need to study the many pages of the Dolby test instructions.

Often it is desirable to perform electrical and listening tests at separate times because their test setups are different. The test program gives users flexibility in configuring the test sequence and defining the order of the tests. It is also possible to execute only parts of the test program and perform the skipped tests later; individual tests can be repeated at any time. Passed, failed and aborted test steps are automatically

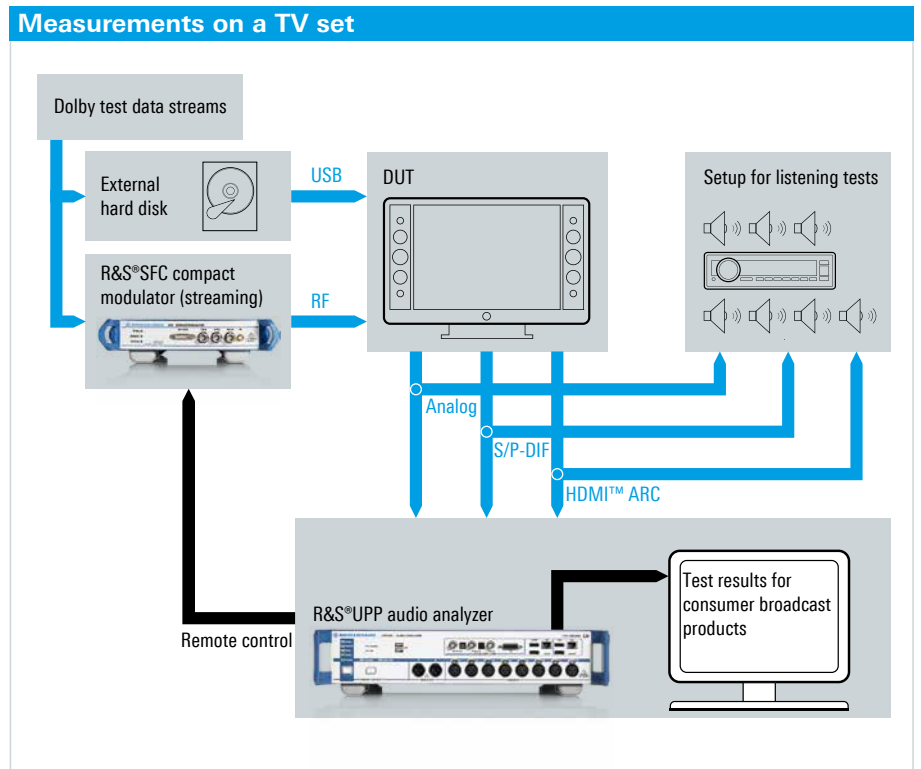
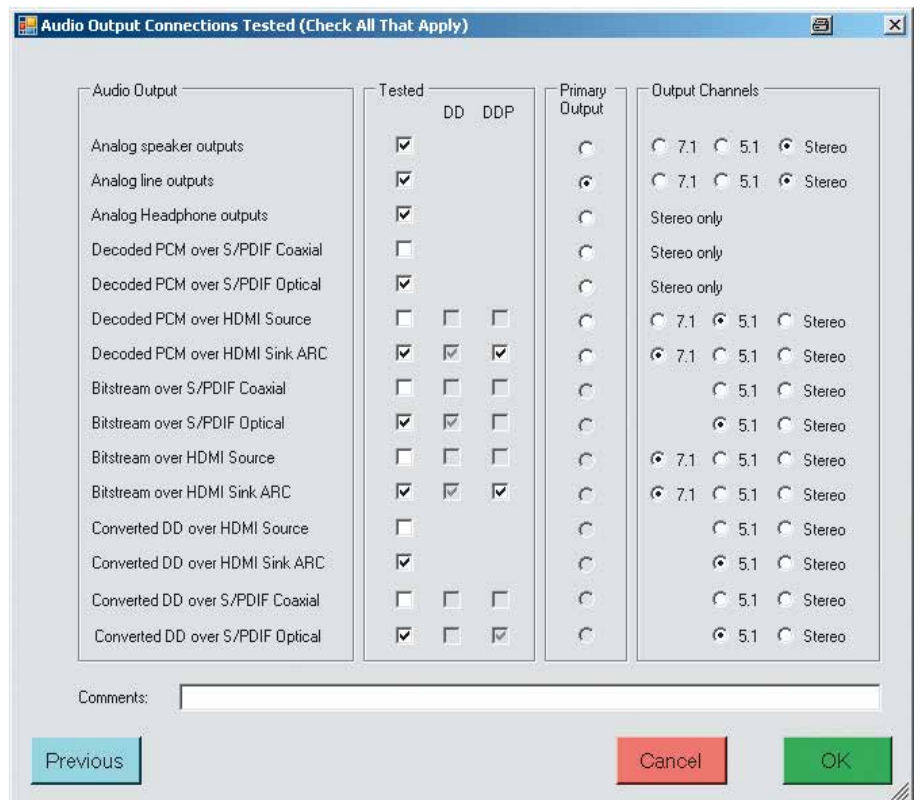

Fig. 3: Typical test setup for Dolby measurements including electrical tests and listening tests on TV sets.

Fig. 4: Entering the audio output configuration.



marked in a list, so that the user always has an overview of which tests still need to be performed (Fig. 5).

The above example begins with the electrical tests. The Dolby test data streams – for the SDK described here, well over a thousand files – are saved to the R&S®SFC compact modulator’s built-in hard disk. Controlled by the test program, each required data stream is started, modulated onto the RF carrier and fed in the suitable format to the TV set’s antenna input.

The measurements are performed on the R&S®UPP audio analyzer. Each test step begins with a window telling the user how to configure the DUT, which connections need to be made and what to do next (Fig. 6).

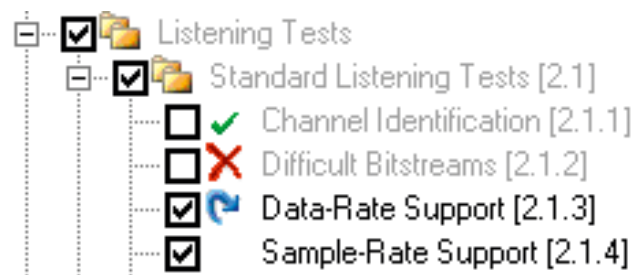
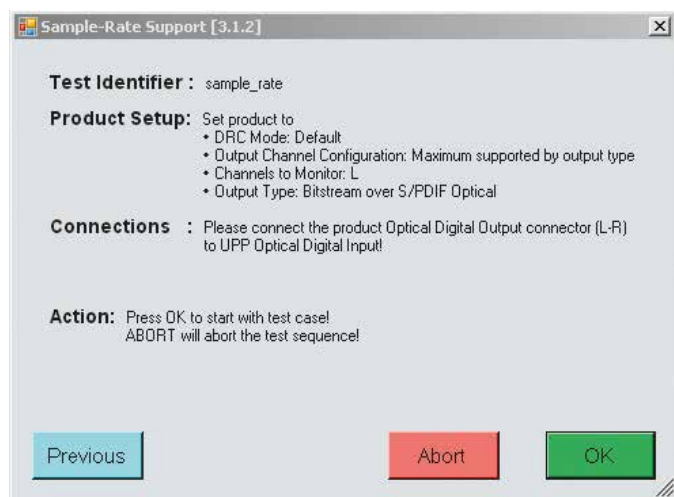

Fig. 5: Passed, failed and aborted test steps are marked.

Fig. 6: Preventing errors: The software provides detailed instructions for the test sequence.



Now the required test case can be started. It often comprises a series of individual tests for which different test data streams are used. Users do not have to bother with all these details; the R&S®UPP audio analyzer and R&S®SFC compact modulator play the right test signals, and the measurements are performed exactly in line with Dolby specifications. This avoids errors in the test sequence, and the entire test procedure takes much less time than with the manual method used in the past.

In most cases, the individual test steps will end with a PASS, and the test result including graphs will automatically be entered in the test report. But if difficulties arise, the user will be informed as to why the test could not be properly performed.

In the Internet-enabled tests, test signals are fed to the DUT’s USB interface, simulating modern TV sets’ capability to receive films via the Internet. Unlike the electrical tests described above, the test signals must be read manually from an external hard disk via the DUT. The program guides users also through these tests and tells them which Dolby test data stream to play from which directory. Measurements are likewise automatically controlled by the R&S®UPP.

With listening tests, the procedure is different. The test signals are played via the R&S®SFC, but now they must be acoustically evaluated by the tester. For example, the tester must listen to the signals to verify whether the loudspeaker assignment matches the coding of the individual channels and enter in a report whether the listening results agree with those stipulated. Here, too, the R&S®UPP audio analyzer’s test program guides the user through the entire test sequence. Once all test steps are completed, the test report merely needs to be sent to Dolby Laboratories.

### Summary

The Rohde & Schwarz test program makes compliance testing easier for Dolby Laboratories licensees. It automates the required tests and helps save time because users no longer have to work through the extensive instructions. The program guides users through the entire test and prevents relevant DUT information from being omitted. The test report is generated automatically.

Klaus Schiffner



# Mobile power measurements using a sensor and an Android™ device

An Android™ smartphone or tablet plus a free app and a Rohde & Schwarz power sensor is all you need to perform high-precision power measurements in the field.



Fig. 1: A tablet or smartphone is sufficient for displaying the results.

## Portable high-precision power measurements

The tried and tested R&S®NRP-Zxx power sensors feature a USB interface. The complete signal processing and calibration data management are integrated in the sensor – a laptop for displaying the results is enough. Thanks to a new app, even the laptop is no longer necessary: The new R&S®Power Viewer Mobile app transforms Android™ smartphones and tablets into base units for high-precision power measurements (Fig. 1). The application supports the most common mobile devices with Android™ operating system version 4.0 or later and can be downloaded and installed free of charge from Google Play™. Besides the R&S®NRP-Z4 USB adapter cable, a conventional USB on-the-go (OTG) adapter is required to connect the sensor.

To ensure maximum measurement accuracy even at low levels, the app can perform a zeroing of the sensor or average the measured values to reduce the effects of measurement noise. In addition, users can use an offset or S-parameter correction to compensate for the influence of attenuators or adapters.

## Ideal for installation and maintenance work

R&S®Power Viewer Mobile supports the complete range of power sensors of the R&S®NRP family. The app enables high-precision average power measurements in a level range from –67 dBm to +45 dBm and in the frequency range from DC to 110 GHz. The light, handy combination of power sensor and smartphone/tablet is easy to use and therefore ideal for installation and maintenance work on base stations and microwave communications systems as well as for all field applications that require precise RF power measurements.

Long battery life is an important aspect of the suitability for mobile use (Fig. 2). Modern mobile devices are able to meet these requirements: The R&S®NRP-Z5x thermal power sensors, for example, can be operated for almost eight hours on a tablet.

For more information on installing and using the app, see the application note “Using R&S®NRP-Z power sensors with Android™ handheld devices” (<http://www.rohde-schwarz.com/appnote/1ma215>).

Michael Kaltenbach

Sensor type	Google Nexus 7	Samsung Galaxy S3
R&S®NRP-Z5x thermal power sensors	> 7 h	> 3.5 h
R&S®NRP-Z11 / -Z2x / -Z31 three-path diode power sensors	> 5 h	> 3 h
R&S®NRP-Z8x wideband power sensors	> 3.5 h	> 2 h

Fig. 2: Maximum operating time in flight mode with medium display brightness and no applications running in the background.

# In brief

## GNSS simulator supports a series of realistic scenarios

Starting in the lab, developers must perform extensive tests on the receivers and components used in satellite-based navigation systems, such as location based services on smartphones, car navigation devices and aircraft control systems. The R&S®SMBV100A vector signal generator from Rohde&Schwarz now offers valuable support. New options expand the functional range of its GNSS simulator by adding a series of realistic scenarios.

The new R&S®SMBV-K101 option allows developers in the automotive and wireless communications industries, for example, to test GNSS receivers for specific effects such as obscuration and multipath propagation. Buildings, tunnels and bridges as well as reflections from concrete and glass surfaces affect the global navigation satellite system (GNSS) signal. This option makes it easy to configure such scenarios, for both stationary and moving receivers.

If the GNSS receiver of a navigation device or smartphone is located inside a vehicle, testing must also take into account the obscuring effect of the vehicle's metal body. The R&S®SMBV-K102 option makes it possible to simulate such obscuring effects and to individually configure receive antenna patterns.

In addition to test scenarios for A-GPS, smartphone developers also have the Assisted Galileo (R&S®SMBV-K67) and

Assisted Glonass (R&S®SMBV-K95) options at their disposal. Mobile radio networks transmit location-specific information to user equipment via A-GNSS so that it can determine the current position faster.

In many cases, navigation devices receive signals of digital communications standards in addition to GNSS signals. The R&S®SMBV100A is the only GNSS simulator on the market that supports mobile radio, wireless communications and radio standards in addition to comprehensive and realistic GNSS scenario simulations. Now, manufacturers of mobile phones and car radios with integrated GNSS receivers need just one signal generator to test multiple functionalities. The R&S®SMBV100A can also be used to perform interference tests on the DUT.

Users in the aerospace and defense industry can use the R&S®SMBV-K92 and -K103 options to simulate the relative attitude of a

flying object as well as its rotation at a rotation rate of up to 400 Hz. This allows developers to perform lab tests to determine how a flying object's different attitude angles and rotary movements affect reception quality. Ground reflections can also be simulated, but not with the R&S®SMBV-K103 option.

The GNSS simulator in the R&S®SMBV100A vector signal generator uses up to 24 satellites to generate signals in realtime for GPS with civilian C/A code and military P code as well as for Glonass and Galileo in different constellations. Users can quickly and easily define their own scenarios to test GNSS receivers under a variety of conditions. They can also call up predefined scenarios. The R&S®SMBV100A is the only GNSS simulator in this market segment that does not require an external PC. As a result, it is easier to automate, and test setup is simple.



The GNSS simulator in the R&S®SMBV100A vector signal generator supports developers of navigation devices by allowing them to simulate realistic scenarios.

# In brief

## R&S®FSH spectrum analyzers now up to 13.6 GHz and 20 GHz

The popular R&S®FSH family of handheld spectrum analyzers from Rohde & Schwarz has two new models: the R&S®FSH13 covering the range from 9 kHz to 13.6 GHz and the R&S®FSH20 covering the range to 20 GHz. For maximum sensitivity, both models are equipped with an amplifier that can be activated. Users can now use the handheld analyzers' wide range of measurement features up into the microwave range.

The portable R&S®FSH spectrum analyzers are well-established, powerful and versatile tools for performing measurements on base stations, for maintaining and installing transmitter systems and for analyzing signal quality. The analyzers have a rugged, lightweight design and are easy to use, making them ideal for applications in the field.

The compact platform integrates numerous measurement functions that can be used to analyze transmit signals and interference, measure power and much more. The maximum application frequency range up to 3.6 GHz and 8 GHz, covered by the R&S®FSH4 and the R&S®FSH8, has been extended. The two new models offer users a frequency range up to 13.6 GHz and 20 GHz.

The R&S®FSH spectrum analyzers support all common wireless communications standards. Their high frequency ranges allow the R&S®FSH13 and the R&S®FSH20 to measure interference signals in wireless communications networks such as UMTS up to the fifth harmonic. The two new models are also perfect for measurements performed during the installation and maintenance of satellite communications systems and radar systems. Last but not least, the handheld spectrum analyzers are easy to use, making them ideal for everyday tasks in the lab, from development work to troubleshooting to EMC diagnostics.

The R&S®FSH13 and the R&S®FSH20 deliver measurement results with a sweep speed roughly four times faster than comparable instruments – a complete sweep up to 13.6 GHz takes just 800 milliseconds. Performance data for digitally modulated signals such as GSM, WCDMA or LTE is available

in just a few button presses. The spectrum analyzers offer the best sensitivity (typically  $-162$  dBm between 8 GHz and 13.6 GHz) and accuracy (typically 1 dB;  $> 8$  GHz) in the handheld category. The dynamic range, which is normalized to 1 Hz, is approx. 145 dB at 1 GHz – up to 10 dB higher than with comparable spectrum analyzers.

These rugged handheld instruments are optimized for applications in the field. They feature a display that is easy to read even in bright daylight, weigh less than 3 kg and run for up to 4.5 hours on an easily replaceable battery. A wizard for configuring automatic test sequences and the ability to assign functions to buttons make them very fast and easy to use.

Application example: Equipped with the R&S®HL300 directional antenna, the R&S®FSH handheld spectrum analyzer can help network operators locate sources of interference.



# Higher frequencies, more power: R&S® BBA 150 broadband amplifiers

The new R&S® BBA 150 broadband amplifier models extend the family's frequency and power range. Rohde & Schwarz now offers amplifiers that meet almost every need: from 9 kHz to 6 GHz and from 15 W to 1700 W. They allow users to perform EMS measurements in line with essential commercial and industrial standards and also comply with the most significant EMC standards in the automotive sector.

## Expanded portfolio for EMS measurements

The broadband amplifiers of the R&S® BBA 150 family (Fig. 1) introduced in the previous issue\* are now also available for frequencies from 2.5 GHz to 6 GHz and at power levels from 15 W to 200 W. These new models expand the range of applications to include EMS measurements in line with commercial standards, for example. Moreover, a new power class of 400 W in the frequency range from 800 MHz to 3 GHz was added.

Users can now configure compact dual-band desktop amplifiers with more than 100 W output power at the 1 dB compression point in the frequency range from 800 MHz to 6 GHz. RF switching functions for input, output and sample ports are optional and can be integrated into the amplifier. Amplifiers for higher power levels are created

by combining the appropriate rackmounts depending on configuration requirements. These rackmounts, together with a central controller, are then installed into a rack.

The amplifiers of the R&S® BBA 150 family can be operated either as standalones or in conjunction with the amplifiers of the R&S® BBA 100 family (9 kHz to 1 GHz). As before, all frequency and power ranges in both amplifier families can be combined into customized solutions to meet specific applications. Fig. 2 shows the Rohde & Schwarz amplifier portfolio. All models feature mismatch tolerance and can handle short-circuiting at the RF end or an open RF output.

Extensive switching functions together with a truly modular design allow seamless integration, application-specific configurability and easy,

\* Broadband amplifiers open up applications in the microwave range. NEWS (2013) No. 208, pp. 51–53.

Fig. 1: The new R&S® BBA 150 broadband amplifier models provide power levels from 15 W to 200 W at frequencies between 2.5 GHz and 6 GHz.



## R&S®BBA100 / R&S®BBA150 frequency and power ranges

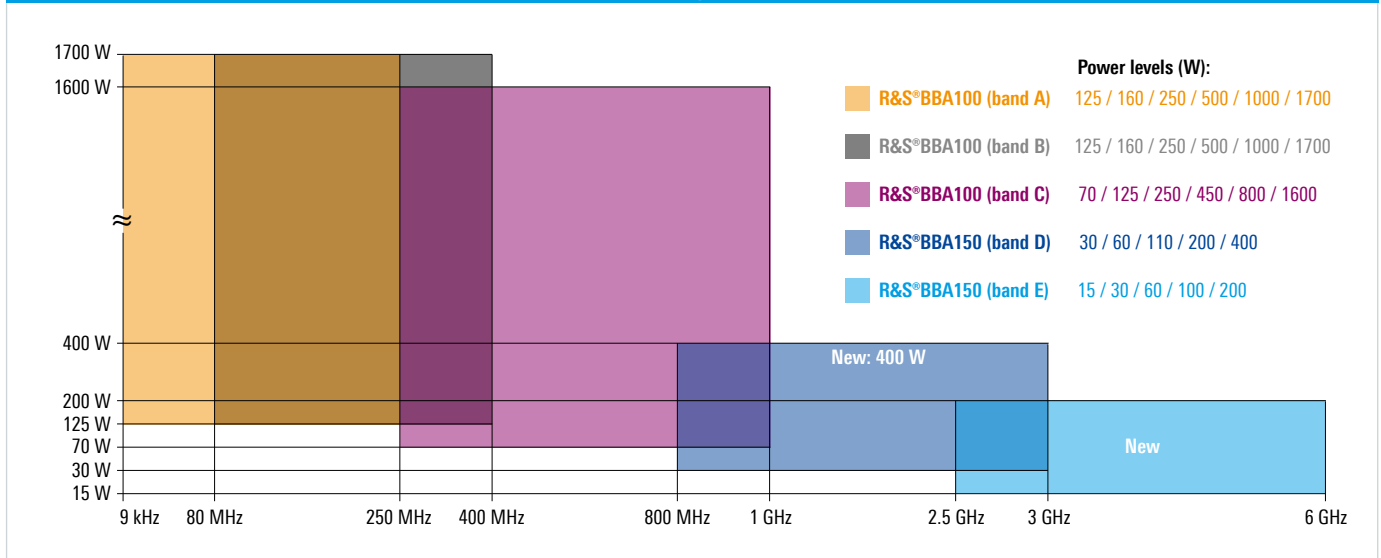

Fig. 2: Due to clever frequency and power range overlapping, the Rohde&Schwarz portfolio now offers broadband amplifiers for almost every need: from 9 kHz to 6 GHz and from 15 W to 1700 W.

straightforward servicing. The Rohde&Schwarz state-of-the-art series production process includes comprehensive quality tests at the module level. As a result, broadband amplifiers based on these modules reliably comply with the warranted data sheet quality parameters. Worldwide spare parts availability ensures rapid assistance in cases where service is required.

### State-of-the-art hardware design

Housed transistors experience parasitic effects at high frequencies, which can lead to lower power output. This is why the new amplifiers up to 6 GHz use unhoused semiconductor dice. The dice are placed in ceramic thin-film circuits on heat-spreader substrate material and are then mechanically and electrically bonded onto the printed board. Special and comparatively lightweight aluminum-copper heat sinks efficiently dissipate the heat. This sophisticated hardware design ensures that electronic components exhibit excellent RF characteristics and a long life.

### New options for the R&S®BBA150

Besides the RF switching options, two additional options are particularly noteworthy. The fast amplifier mute option already known from

the R&S®BBA100 is now also available for the R&S®BBA150. When used with an external TTL control signal, this option makes it possible to blank the amplifier within just a few microseconds.

The transparent I/O option provides special remote control commands for querying and setting states at the rear control port. This allows, for example, a lamp to be turned on and off in order to signal a specific operating state (e.g. “test in progress”), or an electrical contact to be queried or set (e.g. antenna polarization switching).

### Summary

The new R&S®BBA150 broadband amplifier models covering frequencies from 2.5 GHz to 6 GHz – together with those of the R&S®BBA100 series – mean that amplifier systems are now available from 9 kHz to 6 GHz in a variety of power classes. The portfolio covers EMS measurements in line with all essential commercial and industrial standards and complies with the most significant EMC standards in the automotive sector. The R&S®BBA150 broadband amplifiers are also ideal for other microwave range applications, including research, engineering physics, communications and radar.

Sandro Wenzel



Fig. 1: The R&S®BTC broadcast test center is the ideal all-in-one solution for end-to-end testing: It generates all audio/video and broadcast signals and provides a comprehensive set of analysis functions for assessing DUTs.

# High-end test platform for comprehensive testing of audio and video applications

The R&S®BTC broadcast test center is the perfect platform for almost all tests used in the consumer electronics and automotive sectors as well as professional audio/video applications based on broadcast transmission standards.

## Unique end-to-end testing capabilities

The new R&S®BTC broadcast test center (Fig. 1) offers a complete test environment for almost all audio, video and multimedia applications in a single instrument. It generates all necessary signals, simulates transmission and analyzes the audio/video signals from DUTs (typically broadcast receivers) in real-time. The modular and highly scalable test platform supports all global analog and digital TV and audio broadcasting standards and can be optimally adapted to meet different customer requirements. The R&S®BTC can perform complete end-to-end tests over all OSI layers. Thanks to its integrated test application and test sequence control, the R&S®BTC permits users to integrate DUTs in a fully automated test sequence.

## Who needs the R&S®BTC broadcast test center?

Thanks to its versatile options and RF characteristics, a very high bandwidth of 160 MHz and a frequency range up to 6 GHz, the R&S®BTC is suitable for a variety of different applications. Typical users are manufacturers of chipsets, tuners and receivers, test houses, QA testers, manufacturers from the automotive and professional satellite equipment sectors, network operators, T&M equipment leasing companies, regulatory authorities and the A&D industry.

## Audio and video signals in all major formats

The receivers and decoders used in today's multimedia devices process many different audio and video formats. As the number of formats increases, there is a corresponding increase in possible error sources in the transmission path. Developers of receivers and decoders simulate these errors and analyze the DUT's response. To do this, they need a versatile and powerful test platform such as the R&S®BTC that fulfills all requirements with respect to versatility and flexibility when generating digital audio/video streams and simulating transport stream transmission.

## Multimedia generator – the multitasking in the R&S®BTC

The R&S®BTC software-based multimedia generator offers a wide range of applications. It generates audio/video signals based on elementary audio and video streams. The optional recording function plus bitstream and elementary stream player allows users to record and replay both transport streams and bitstreams. In addition, the multimedia generator can modify existing, newly generated or externally fed transport streams via ASI or IP, and then combine these streams into a new multiplex signal. Errors can also be injected as needed.

## Error injection and TS multiplexer functionality – stress tests for decoders

The R&S®BTC sequencer can be used to configure dynamic switchover scenarios and to define the timing and

sequencing of these scenarios. Errors can be injected into the MPEG-2 transport streams without interruption at the bit, byte, packet and table level, making it possible to precisely define critical test sequences for decoder stress tests and to reproduce them at any time.

The R&S®BTC remultiplexer uses existing or externally fed transport streams to generate a new multiplex signal and the corresponding new tables (Fig. 2). It supports both ASI and IP input interfaces as well as the internal bitstream and elementary stream players, ensuring optimum flexibility for creating and modifying existing MPEG-2 transport streams.

## Gateway functionality – access to all parameters

The multimedia generator has an integrated gateway that offers indispensable functions for generating the required transmission parameters, such as those for DVB-T2. Thanks to the software-based T2-MI gateway, users can generate the T2-MI stream required for the relevant transmission parameters directly in the R&S®BTC and feed the stream to the DVB-T2 realtime coder. All parameters and settings over the entire transmission chain can be modified at any time. The software-based multimedia generator is also prepared for future gateways using different transmission standards.

## Analog signals – still in demand

For analog transmission standards, an audio player is available for replaying WAV and WV files. The multimedia

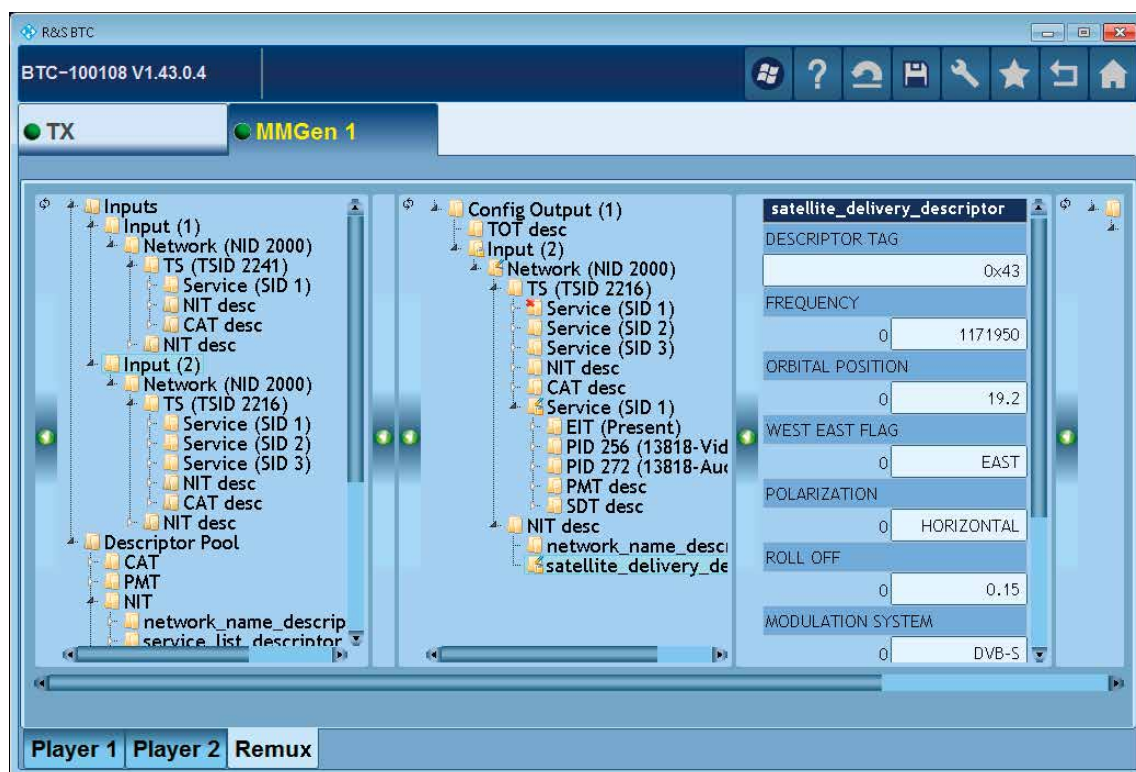

Fig. 2: Using the remultiplexer, transport streams can be modified in realtime without interruption. Table parameters, e.g. of a network information table (NIT), are easily modified.

generator can also generate analog signals. It generates test patterns for the PAL, NTSC and SECAM standards, supporting all global analog broadcast standards.

### Signal generation – with unrivaled RF quality

There has been a steady increase in both the number of integrated transmission standards and the data transmission rates for HD and 4K video resolutions used in the development of tuners, receiver chipsets and terminal equipment. However, more emphasis is also being placed on higher frequencies for broadband and yet relatively untapped frequency ranges. As a result, receivers require excellent RF quality parameters. Thanks to its exceptional RF performance, the R&S®BTC is the first choice for these tests because it generates all global digital and analog cable, satellite and terrestrial TV and audio broadcasting standards.

As a high-end broadcast signal generator, the R&S®BTC provides two independent realtime RF signal paths, each with a modulation bandwidth of 160 MHz for generating internal signals. Externally fed analog I/Q signals have a bandwidth of up to 2 GHz, depending on the set frequency. When defining the internal RF paths, the user can choose between 3 GHz and 6 GHz. Hybrid configurations using both 3 GHz and 6 GHz in

a single instrument are also available. The two either coupled or independent RF paths can also be operated and configured independently of one another. Consequently, the FPGA realtime coders can be loaded with two different or the same two transmission standards.

The R&S®BTC features very low SSB phase noise of up to  $-135$  dBc (1 Hz) and excellent signal filtering. This becomes obvious in the generated RF signals, which exhibit excellent shoulder attenuation and modulation error ratio (MER) values. When using the low phase noise option, even better SSB phase noise values of up to  $-139$  dBc (1 Hz) are available.

The output signal level is set using the integrated electronic step attenuator, which provides a broad interruption-free range. The output power for each RF path is a maximum of  $+18$  dBm, providing a sufficient level range for all broadcast signals and interferer signal scenarios.

### Simulation of the entire physical transmission channel

Portable and mobile terminal equipment experience continually changing receive conditions. These situations must be simulated under realistic realtime conditions during



development so that the receivers can be optimized. The R&S®BTC offers a variety of noise sources, predistortion at the transmitting and receiving ends, a powerful fading simulator suitable for MIMO scenarios and multiple ARB generators. The two RF paths can also be used to simulate single-frequency networks (SFN) and diversity scenarios.

Signals from a variety of noise sources, including broadband or bandwidth-limited Gaussian noise, impulsive noise and signals generated by a 10 MHz phase noise option, can be combined and added to the wanted signal. Users can enter defined phase noise traces directly via touchscreen, and the R&S®BTC calculates the new coefficients and phase noise trace internally.

The integrated predistortion function simulates linear and non-linear predistortions at the transmitting and receiving ends. It can also be used to change the signal's phase and group delays. As a result, the R&S®BTC output signal can be optimally adjusted to match amplifier characteristics. Simulation of satellite transmission scenarios using IMUX and OMUX traces is also possible (Fig. 3). Even tuner input characteristics can be simulated using this function.

The FPGA-based fading hardware offers up to 40 paths per RF channel and covers all DAB SFN and DVB-T2 MISO tests. The 40 fading paths provided by two fading modules can be internally split over four transmission paths for simulating 2x2 MIMO scenarios. The R&S®BTC is already today the ideal reference signal source for evaluating DVB-T2 MIMO applications.

The two independent RF channels and their transmission simulations are also ideal for complex multidiversity scenarios. The oscillators for the two modulators can be phase-locked as needed.

### Multiple ARB generator – easy generation of complex interferer signal scenarios

The main challenges faced by manufacturers of receiver chips and receivers, certifiers and test houses lie in testing the receive characteristics for broadband and multistandard terminal equipment. They encounter interferer signals as well as the new transmission standards that are intended to minimize the effects of these interferences.

Fig. 3: Transmission simulation based on the input and output multiplexer (IMUX and OMUX) in a satellite transponder.

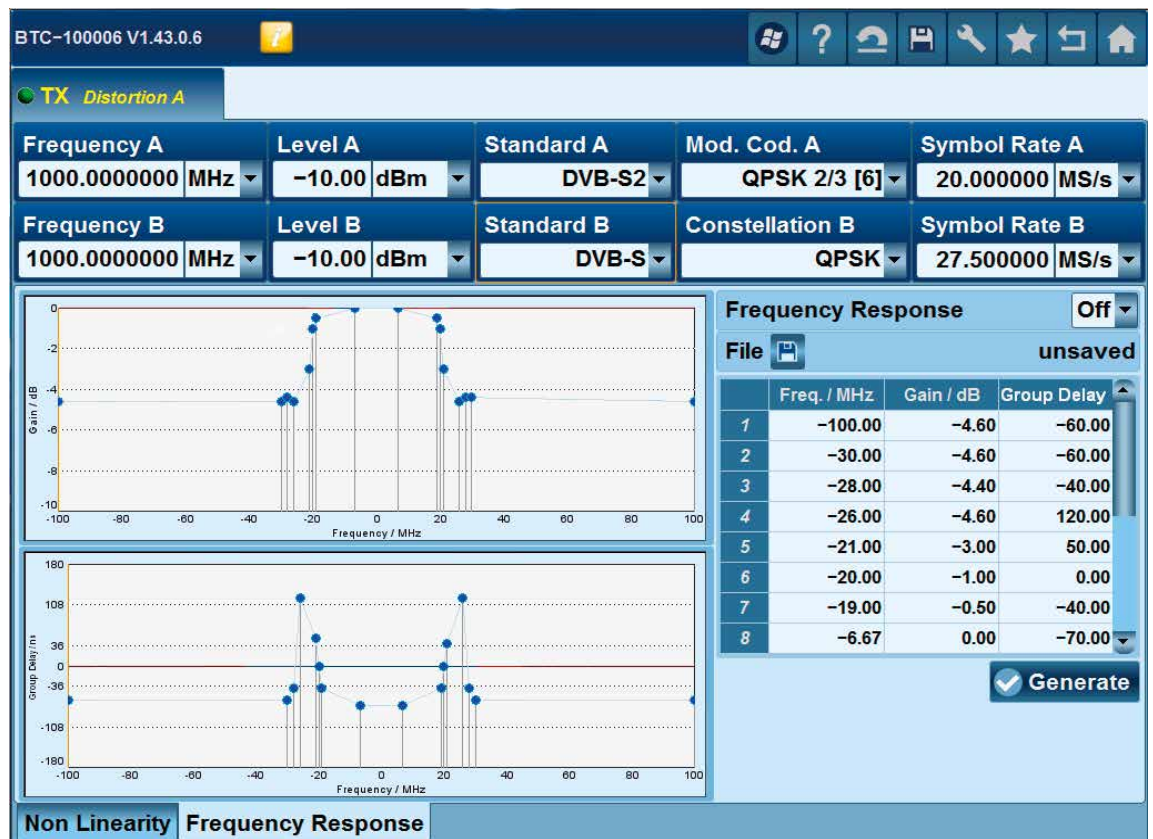

As an alternative to signal generation using realtime coders, the flexible multiple ARB generators in the R&S®BTC can also be used to replay synthetic signals with a length of up to 1 Gsample. Each RF path is equipped with an ARB generator that can generate up to eight independent interferer signals, making it possible to generate complex and realistic interferer scenarios (Fig. 4). The large memory depth allows broad-band satellite or whitespace signals to be generated and then added internally to a wanted signal generated by the realtime coder. The user can position each individual interferer signal within a 160 MHz bandwidth and set the level to a C/I ratio of up to 60 dB.

The R&S®WinIQSIM2™ software is available for simulating digital dividend or whitespace scenarios. The software generates the I/Q signals and supports numerous wireless communications standards. Together with the R&S®BTC ARB generator, suitable interferer signals are generated and added to the wanted signal.

The R&S®CLG cable load signal generator is an excellent addition to the R&S®BTC when working with full channel load scenarios in cable applications that require a high-quality RF wanted signal and many adjacent channel signals. The R&S®SLG satellite load generator complements the R&S®BTC for satellite applications (see page 38).

### A/V analysis and signal generation modules – digital and analog

Testers of modern audio/video components are confronted with a variety of interfaces and formats. Designed as an extensible platform, the R&S®BTC broadcast test center can be expanded with modules from the comprehensive R&S®VTC video tester portfolio to meet all T&M requirements with respect to signal generation and analysis both now and in the future (Fig. 5). The R&S®VTC portfolio includes analog and digital modules with electrical and optical interfaces that are plugged into the R&S®BTC.

As a result, DUTs can simply be connected to the R&S®BTC via their interfaces, including CCVS, Y<sub>P</sub>P<sub>R</sub>, HDMI and SPDIF. This is the basis for additional software-based audio/video testing options that are based on the installed modules.

Integrating a DUT in the test environment with simultaneous audio/video signal generation and analysis makes it possible to perform fast and objective picture failure point (PFP) analysis, ensuring an automated, convenient and reproducible assessment of picture quality.

Additional functions and options of the R&S®VTx modules and the new generator module are described on page 50 of this issue.

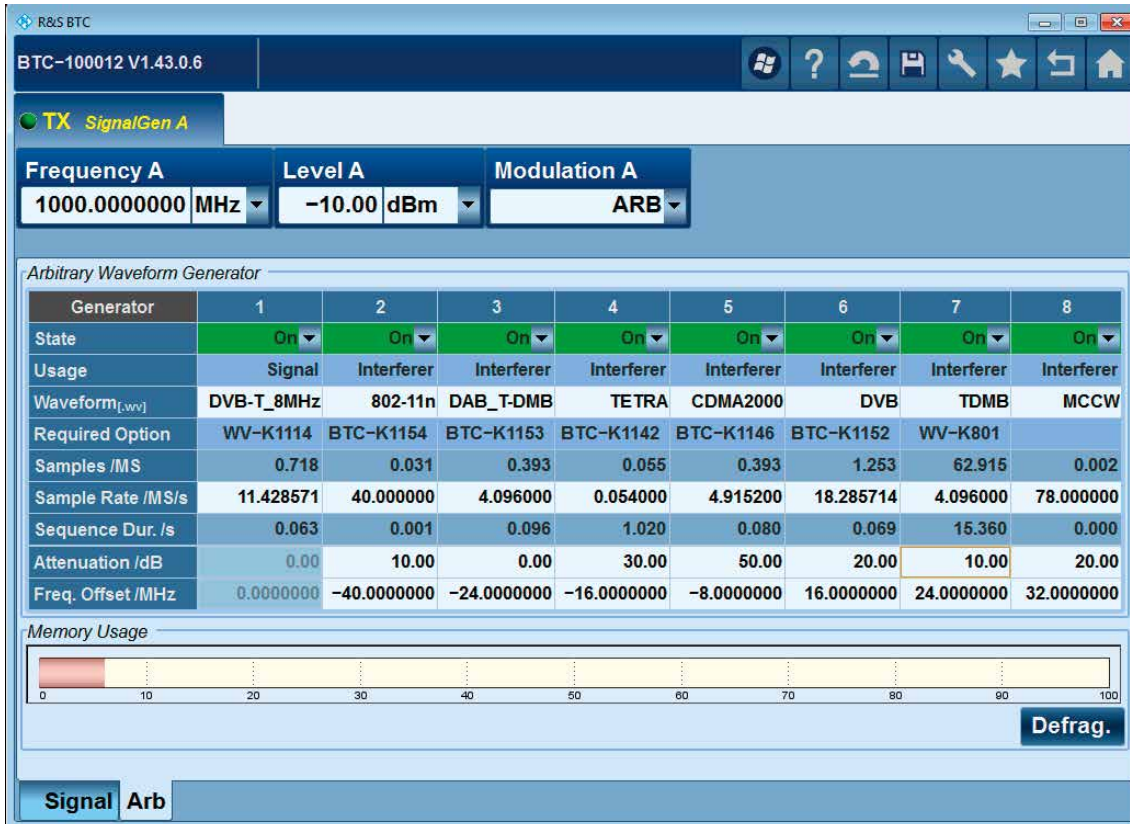

Fig. 4: The multiple ARB generator can generate up to eight different signal spectra for simulating a variety of channel assignments.



Fig. 5: With its wide range of plug-in modules, the R&S®BTC can be perfectly adapted to any application.

### Versatile interfaces – for every need

In addition to the widely used ASI and ETI interfaces, the real-time coders in the R&S®BTC also provide an IP interface for broadcast applications as specified for DVB-T2, DVB-C2 and DVB-S2. This interface can be used to feed in external audio, video and data.

Developers of chips and tuners need I/Q data to be highly flexible in terms of data rates and data formats. The R&S®BTC is therefore equipped with multiple digital I/Q interfaces and flexible data input and output for ideal test and design capabilities (Fig. 6).

### Ready for the future – modular and scalable

New and constantly changing development requirements, new and enhanced standards, time-limited projects, preproduction and small batch production – all of these present huge challenges to all parties involved, not only financially, but also in terms of the T&M equipment logistics. These challenges are an ideal task for the flexible, intelligent R&S®BTC. Its modular and highly scalable platform design is excellently suited for a variety of broadcast applications. It eliminates time-consuming and costly test setups that require a large number of individual test instruments. The future-ready modular design ensures expandability, also for future modules (Fig. 7).

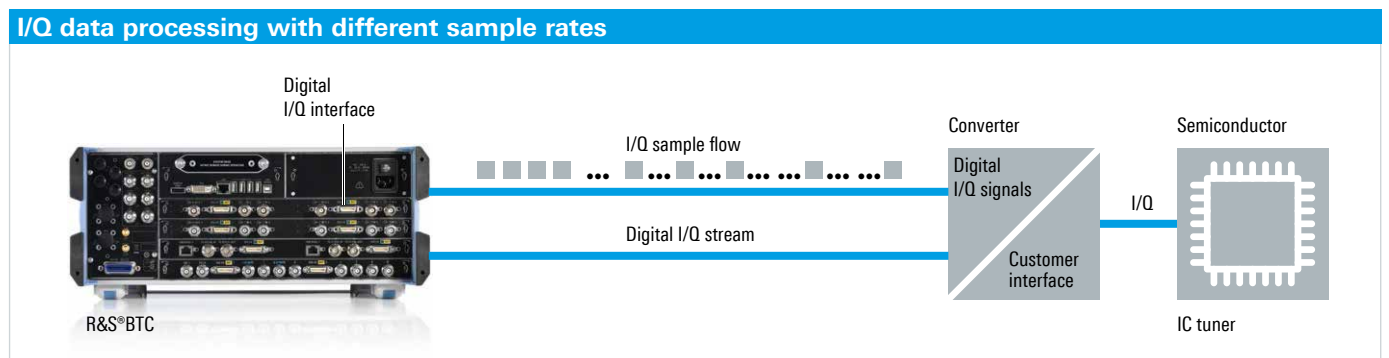

Fig. 6: The digital I/Q interfaces for the R&S®BTC enable I/Q data processing with different sample rates.

The R&S®BTC also scores top marks for its serviceability. Hardware modules can be installed or replaced directly on site. Even the hard disk and processor modules can be swapped out to keep the platform up to date.

The new, flexible software licensing concept opens a wide range of options for users and T&M equipment leasing companies. The following licenses are available:

- **Floating licenses** for two-path instruments can be intelligently activated on the path that is currently being used
- **Permanent licenses** can be activated for each path
- **Portable licenses** can be transferred from one R&S®BTC to another via the Rohde&Schwarz license server
- **A time-limited licensing model** is available for projects lasting only one or three months

### Easy operation – touchscreen, remote or automated

The R&S®BTC is easy to use thanks to its capacitive 8.4" touchscreen and specially designed GUI. A hierarchical design featuring individual function blocks simplifies navigation and provides users with an overview of the entire test setup at any time, even when complex test setups are used.

Since the R&S®BTC is compatible with the remote control commands used by the R&S®SFx family of TV test transmitters, it can be easily integrated into existing test environments.

### Fully automated internal test sequences – fast and reproducible

Ever shorter development, test and product introduction cycles are now the norm. At the same time, the effort



Fig. 7: The future-ready modular design ensures expandability, also for future modules.

Fig. 8: Automation reduces test times and delivers reproducible results. This example shows the D-Book Minimum Requirement Specifications test case.



required for maintaining test depth and generating test reports is increasing. This makes automated, reproducible test cases essential. The R&S®AVBrun sequencer tool is available for automating test sequences. This tool can be used to configure proprietary test plans by selecting the tests to be completed and defining their sequence. Once the test sequences are defined for individual test tasks, they run automatically.

In combination with optional test suites, the R&S®AVBrun supports full test automation. A test suite based on the Digital TV Group (DTG) D-Book contains all predefined test cases required for each test (Fig. 8). The test cases control the defined functions in the R&S®BTC, enable the required signal and set the generator to the specified frequency, level and transmission standard. They also launch the required transmission simulations with the corresponding C/N in the AWGN generator and the required fading profile, add interferer signals as needed and assess the results using the integrated audio/video analysis options.

The user chooses which test cases are to be enabled and disabled in the sequence. It is even possible to define test loops consisting of individual test cases or specific sequences. Turn-around times are reduced, and completed tests can be reproduced and the reports displayed at any time. The test reports are available in various formats, making time-consuming certification and logo tests both fast and dependable. The currently available D-Book test suite will be supplemented in the near future with E-Book and NorDig suites.

### Summary

The R&S®BTC broadcast test center is an all-in-one solution that can be used to perform current and future tests in almost all audio and video transmission modes, and to subject receivers to tests extending far beyond what is normally required by the standards. The test platform can be quickly and flexibly adapted to new and changing test requirements at any time.

Ralph Kirchhoff

# Multichannel signal generator simulates satellite TV band with full channel load

While cable TV channels have always been close together, terrestrial programs must now squeeze tighter together in view of the digital dividend. In the case of satellite TV, it is also necessary to make efficient use of the available spectrum, although the frequency bands appear to be very ample. The full load, minimized guard bands and small rolloff factors make special tests necessary for the receivers and broadcasting equipment. The new R&S®SLG satellite load generator is the ideal signal source.

## Multichannel signal generation in a lab setting

Signal generators capable of generating a satellite TV band with full channel load are required for testing and optimizing the sensitivity and selectivity of satellite receivers (see box). Until now three different approaches have been available, each with specific technical or economic drawbacks. One approach is to use a sufficient number of satellite TV monitors and aggregate their output signals. Such a setup is complicated to configure and calibrate and also relatively costly due to the number of modulators. Alternatively, an arbitrary waveform generator with sufficient bandwidth can be used. However, it is no easy task to generate a suitable I/Q waveform file for multiple satellite TV transponders. Any ever so small

change to the configuration makes it necessary to create a new file, which makes this approach inflexible. Last but not least, it is possible to use a broadband noise generator that simulates the loaded band with rough approximation.

The new R&S®SLG satellite load generator (Fig. 1), a multichannel signal generator for satellite TV, makes no compromises. It generates up to 32 satellite transponder signals simultaneously. The symbol rate, FEC, frequency and level can be individually set for each transponder (Fig. 2). Up to 16 transponders can transmit live video signals. The R&S®SLG satellite load generator avoids the drawbacks of the previous solutions. It is also energy-efficient and saves space thanks to its 19" 1 HU housing.

### Important receiver tests: selectivity and sensitivity

Selectivity and sensitivity determine the performance of every RF receiver, and also that of satellite tuners. Selectivity defines how well a receiver can receive the wanted signal in the presence of other signals on adjacent channels. In bands with full channel load, this is particularly challenging because the receiver must be able to decode the wanted channel while suppressing the others.

Sensitivity indicates the minimum level at which the wanted signal can still be processed by a receiver. A band with full channel load impairs satellite receiver sensitivity since the harmonics and intermodulation products from some other channels will inevitably scatter into the useful channel as additional noise. The linearity of all transmission path components is crucial, because it determines the magnitude of the harmonics and intermodulation products.

Fig. 1: R&S®SLG, the compact multichannel signal generator for satellite TV.



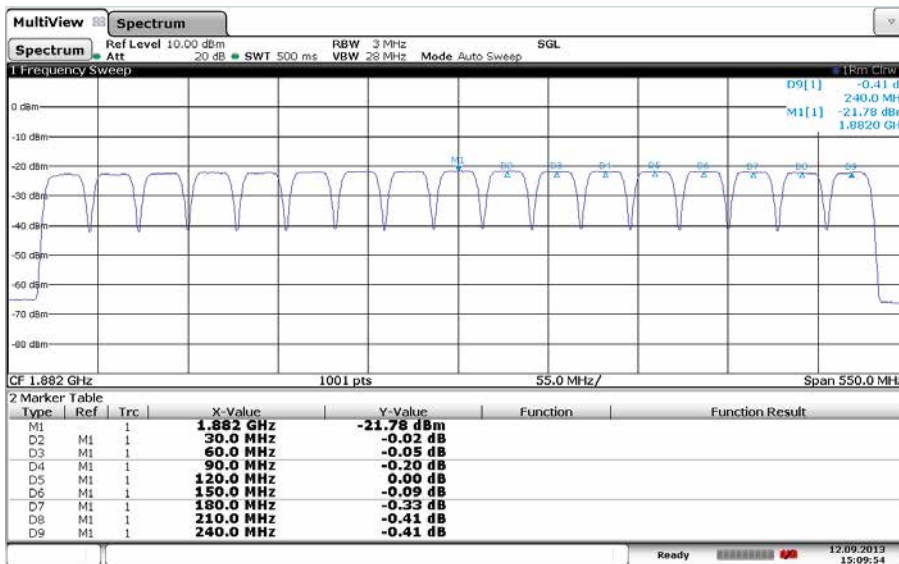
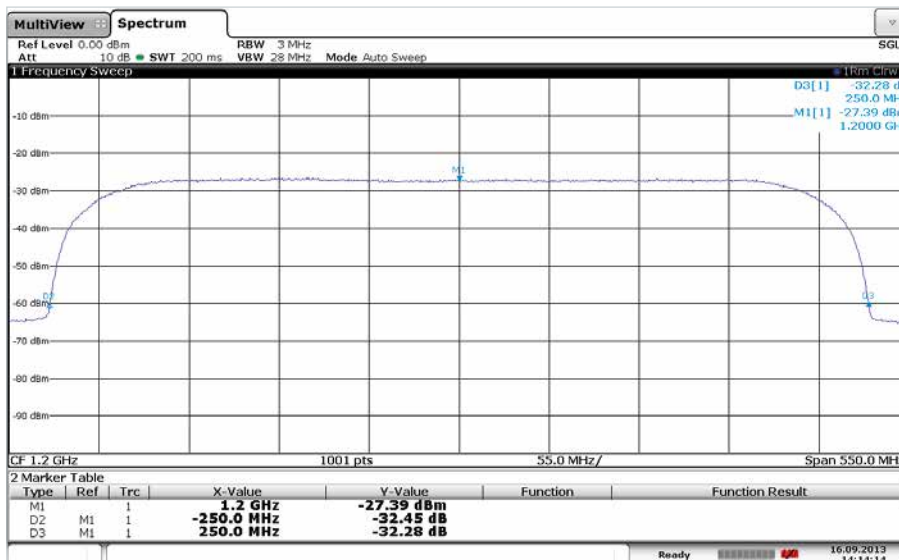

Fig. 2: R&S®SLG output signal: 17 DVB-S transponders with 22 Msymbol/s each.

Fig. 3: Transponder for DVB-S2 wideband with 416 Msymbol/s.



### Applications: consumer electronics to military

It's not just about RF tests. All components in a satellite transmission path must be able to handle a large number of signals with high data rates. During their development, conditional access software, set-top box middleware and headend transcoders all undergo comprehensive stress tests. These tests require a sufficient number of satellite

TV signals with a high data rate and decodable video and audio content – a task for the R&S®SLG satellite load generator. Satellite TV standards are gaining importance also for military applications. Intelligence systems, e.g. unmanned aerial vehicles, transmit high-resolution video signals. Many video signals of this variety arrive in the control center all at once and must be processed and evaluated in realtime. The R&S®SLG

is the ideal signal source for developing and testing the systems used for these applications. Last but not least, the satellite load generator is suitable for assessing the group delay of a satellite transmission path. To handle this task, it produces a multitone CW signal that is measured by a vector signal analyzer, e.g. the R&S®FSW, after passing through the uplink – transponder – downlink chain. The measured frequency response of the group delay is used to set the modulator predistortion, i.e. for the precorrection of the complete transmission\*.

### Equipped for future DVB-S2 extensions

The R&S®SLG satellite load generator operates in the satellite IF range from 250 MHz to 3000 MHz with a modulation bandwidth of 500 MHz. It generates up to 32 transponders for DVB-S/-S2 or ISDB-S/-S2 with a maximum symbol rate of 30 Msymbol/s each, in a 500 MHz subband. Alternatively, up to eight transponders with maximum symbol rates of 72 Msymbol/s are possible. This mode has been provided to cover the planned extension of the DVB-S2 standard, which will specify transponders with these bandwidths. However, the development toward higher bandwidths is not yet complete: Transponders with up to 500 MHz bandwidth are planned for the future under the heading of DVB-S2 wideband. The introduction of such an extremely wideband signal will completely do away with the guard bands between today's transponders, and optimal use will be made of the available frequency band (Fig. 3). The R&S®SLG satellite load generator already supports this modulation format. It has the technological leadership in the simulation of satellite TV transponders and is a sound investment for the future.

Peter Lampel

\* Group delay measurements: precise, fast, wideband. NEWS (2013) No. 208, pp. 43–45.

# In brief

## R&S®SFC compact modulator and R&S®SFC-U USB compact modulator

**The R&S®SFC compact modulator and the R&S®SFC-U USB compact modulator are economical multistandard signal sources. They support realtime coding for all established digital and analog TV and audio broadcasting standards. The R&S®SFC is equipped with a built-in computer, making it ideal for standalone operation. The R&S®SFC-U is a USB device designed for use with a PC.**

The R&S®SFC and R&S®SFC-U have an extremely compact design. Though small in size, they are full-featured TV and audio broadcasting signal generators with integrated transport stream player, audio/video generator and optional noise source.

The ½ 19", 1 HU R&S®SFC is the most compact standalone TV and audio broadcasting signal generator on the market. It is ideal for rack installation in production test systems. It is controlled using remote desktop via LAN or remotely with SCPI commands. The instrument can also be operated directly with a mouse, keyboard and monitor.

The free R&S®Central TX System Control software has been designed specifically for controlling production test systems with multiple R&S®SFC modulators. The software allows users to conveniently control and monitor the generators in a test system via LAN. The software graphically displays the system configuration and indicates the current system status.

The R&S®SFC-U USB compact modulator offers the same signal generator functions as the R&S®SFC in an even smaller housing, saving a lot of space on the lab bench. The R&S®SFC-U is connected to the USB port of a host PC and controlled from the PC. Its wide range of functions make the R&S®SFC-U ideal for developing software

and hardware for TV sets and set-top boxes. In addition, both instruments support tried and tested functionality found in the Rohde&Schwarz high-end broadcast signal generators, such as external reference, digital I/Q input, 1 PPS input and ASI transport stream input.

Key features of the two instruments:

- ▀ High-precision modulator with MER > 40 dB
- ▀ VHF and UHF frequency range, optionally up to 3 GHz
- ▀ Level range from 0 dBm to -31.5 dBm, optionally to -110 dBm
- ▀ Transport stream player and audio/video generator
- ▀ AWGN generator

The two economical multistandard signal sources save a lot of space – both in racks in production test systems and on the lab bench.





# Solid-state R&S®THU 9 up to 50 kW succeeds DTV IOT transmitters

In the past, inductive output tube (IOT) transmitters handled all DTV transmissions at higher power levels up to 50 kW. However, their use will soon be discontinued as powerful alternatives assume control of the market: The R&S®THU 9 family of solid-state transmitters now generates output power of up to 50 kW and offers numerous advantages.

\* Efficiency redefined: the R&S®THU 9 UHF high-power transmitters. NEWS (2011) No. 204, pp. 46–52.

## The advantages of solid-state technology

The R&S®THU 9\* family of high-power UHF transmitters (Fig. 1), which is based exclusively on solid-state technology, has been expanded to achieve output power of up to 50 kW for ATSC. It now offers output power levels from 1 kW to 50 kW. The transmitters use Doherty technology, a technology increasingly recognized as superior by network operators around the world (see box on page 42) and offer numerous advantages over IOT transmitters.

## Simpler and more secure transmitter systems

IOT transmitters operate at voltages of up to 30 000 V. Both specialized equipment and high safety precautions are required when replacing tubes. For example, two technicians are needed on site when working on active systems with high voltages.

The R&S®THU 9 high-power transmitters are significantly easier to maintain. Technicians require neither special equipment nor specialized training. Thanks to the use of solid-state technology, the transmitters operate at the standard AC supply voltage of only a few hundred volts.



Fig. 1: In this configuration, the R&S®THU 9 family of high-power UHF transmitters generates output power of up to 50 kW for ATSC – with a design based exclusively on solid-state technology.

### Greater redundancy

One of the most important requirements placed on a transmitter is a high degree of redundancy to ensure interruption-free continuous operation. This is why conventional transmitters are frequently equipped with two tubes. Loss of one or both of the tubes will cause the output power to be reduced by one-half or to fail completely.

Solid-state transmitter systems, however, have significantly more core components of the same type, drastically increasing redundancy. If one of the power amplifiers in a 25 kW transmitter fails, for example, the output power will be

reduced by less than 10 %. Failure of one of the many transistors will still leave about 99 % of the output power. If a power supply for an R&S®THU9 amplifier fails, the output power will not change at all, as the system design ensures full power supply redundancy.

### Less maintenance and lower service costs

The reliability of the components in a transmitter system has a significant effect on both maintenance costs and service frequency. The less service a system requires and the less complicated the required spare parts, the lower the costs will be in the long run.

### Rohde & Schwarz transmitters with Doherty technology: in demand around the world

The basic principle behind Doherty technology is to split signal amplification into two paths, i. e. the main amplifier and the peak amplifier (see also article on page 44). As an advantage, the main amplifier amplifies only the average signal and no power reserves for peak signals are required in this path. The peak amplifier is active only when peaks occur in the signal. As a result, efficiency can be increased by approximately 15 % as compared to AB amplifiers.

The Rohde & Schwarz portfolio of Doherty-based transmitter systems is the broadest in the market. All conventional standards are available, including ATSC, DVB-T / DVB-T2 and ISDB-T / ISDB-T<sub>B</sub>. This is just one of the reasons why so many transmitter network operators around the globe have decided on systems from Rohde & Schwarz (Fig. 2).

### Transmitters with Doherty technology all over the world

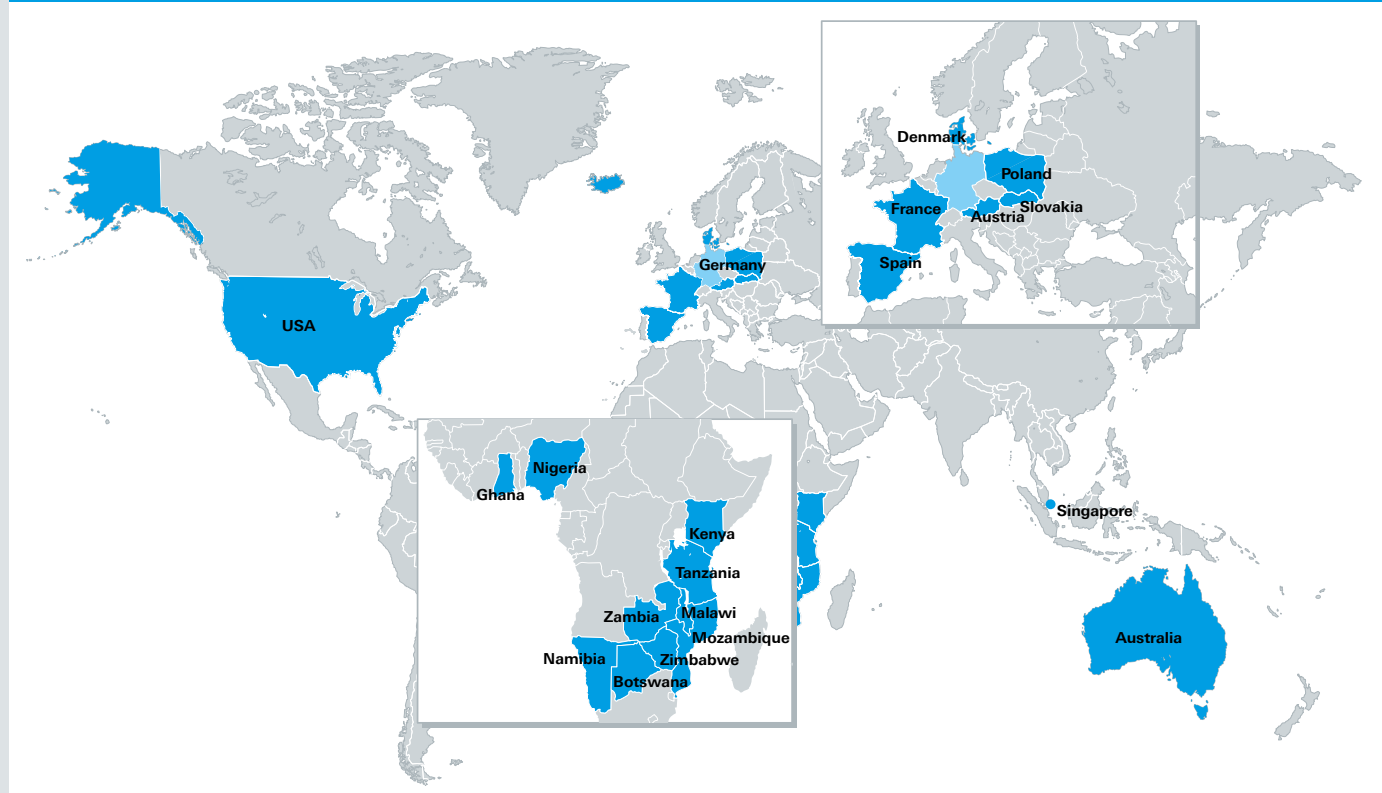
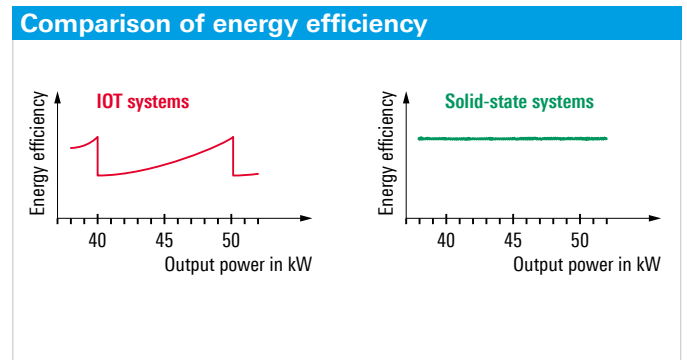

Fig. 2: Rohde & Schwarz transmitters using Doherty technology have quickly conquered the market in many countries.

Fig. 3: Comparison of the energy efficiency of IOT and solid-state transmitters. Solid-state transmitters are superior because their energy efficiency remains nearly the same even with a decrease in nominal power.



### Recent successes of the R&S®THU9 high-power transmitters

Following the introduction of Doherty technology, and in particular after the expansion of the R&S®THU9 product line to provide output power up to 50 kW, two of the largest US TV network operators decided in favor of the superior solid-state technology. Numerous transmitters have since been installed in various states in the US. An ordered transmitter, which generated a great deal of attention at NAB in Las Vegas, successfully went on air at 23 kW output power. The customer was impressed by the proven efficiency of the system and the quality of the transmitted TV signal.

The first transmitter system with more than 40 kW output power was ordered only two months after its premiere at NAB. A powerful proof of how network operators are convinced by the advantages offered by the R&S®THU9.

Replacing the expensive and heavy tubes every five to eight years requires specialized technicians and tools. The R&S®THU9, however, needs only comparatively small and simple components to be stocked: Amplifiers, power supplies and transistors take just a few steps to replace.

### Choice of output power levels at comparable energy efficiency

When IOT systems operate below nominal power, they lose their energy efficiency. For high energy efficiency, these systems must operate at nominal power. Nominal power levels depend on the tube type and circuitry. Because tubes are available for only a few power rating classes, there are very few power levels between 15 kW and 50 kW at which IOT systems operate optimally (Fig. 3).

Here, too, solid-state transmitters have the clear advantage. Thanks to the number of amplifiers used, the output power can be precisely scaled to fulfill practical requirements, enabling efficiency of up to 42 % for ATSC. Even if the nominal power is reduced by 10 %, the transmitters' energy efficiency remains almost the same, changing by only about 1 %.

### Summary

The advantages offered by transmitter systems with both solid-state and Doherty technology are so convincing that replacement of IOT transmitters will continue at a rapid pace. Offering the market's broadest portfolio, Rohde&Schwarz is ideally positioned to respond to this transition – offering a transmitter to fit every scenario and all major standards.

Olaf Fahrenkroog; Jürgen Steinheber

# Optimizing efficiency of high-power TV transmitters

Various methods are available to optimize the efficiency of transmitters. This article examines why Rohde & Schwarz has adopted the Doherty concept and why this choice helped to make the company's transmitters such a big success around the globe.

## Optimizing efficiency – but how?

Today's advanced high-power transmitters are almost exclusively equipped with solid-state amplifiers. Although recent years have brought major advances in the efficiency of these broadband amplifiers, which normally operate in class AB mode, the results achieved for OFDM signals are still only in the rather moderate range of 25 % to 28 %. Efficiency is defined as the ratio of the average emitted RF power to the power consumed from the power grid. In order to reduce transmitter system energy costs and CO<sub>2</sub> emissions, manufacturers are working to significantly increase the efficiency of solid-state amplifiers. Suitable architectures have already existed for many years, but their application was simply not feasible in the past due to the large RF bandwidths (e.g. band IV/V from 470 MHz to 862 MHz) and signal bandwidths between 6 MHz and > 20 MHz.

Recent advances in solid-state and circuit technology as well as in digital signal processing are now making it possible to exploit these architectures for use in amplifying digital broadcast signals. Besides the increase in efficiency, however, there are certain disadvantages that must be taken into account during transmitter development. It is important to look beyond the reduction in energy costs and keep in mind the total costs during the entire lifetime of the transmitter. These costs consist of the capital expenditure (CAPEX) and most importantly, the operating expenses (OPEX) including energy, maintenance, repair and logistics costs.

## Switched-mode power amplifiers (SMPA)

The SMPA architecture achieves the highest efficiency among all of the solutions presented here. However, it also has the largest impact on the transmitter system, because it affects almost all of the transmitter components including modulators, excitors, amplifiers and filters. Amplifiers based on this concept use high switching frequencies in the transistor output stage, making it necessary to use GaN semiconductors. This technology has not yet attained the level of maturity required for use in commercial high-power transmitters. Suitable power semiconductors are not yet available and expected to cost significantly more than conventional LDMOS transistors. Accordingly, switched-mode power amplifiers currently cannot compete in the price-sensitive broadcast market and will require more years of development before they become relevant. The capital expenditure will be significantly higher than for conventional transmitters.



Fig. 1: R&S™TMU9 transmitter system, configured for three transmitters with six R&S™PMU901 amplifiers based on Doherty technology. Each transmitter delivers 1.14 kW.

## Envelope modulation

With this method, the supply voltage of the RF power transistors is modulated with the envelope of the RF signal (Fig. 2). In order to ensure the high quality of an OFDM-modulated signal, e.g. in terms of the modulation error ratio (MER), the supply voltage must track the envelope with adequate speed and the envelope must remain in sync with the modulated RF drive of the transistor. In case of a mismatch, the MER needs to be corrected using adaptive precorrection. This involves complex control circuitry when multiple transistors are connected in parallel in an amplifier. The use of complex envelope modulators requires a significantly larger number of (power) components (resulting in lower MTBF) and results in significantly higher production costs compared to class AB amplifiers. The efficiency of the output stage is highly dependent on the efficiency of the envelope modulator.

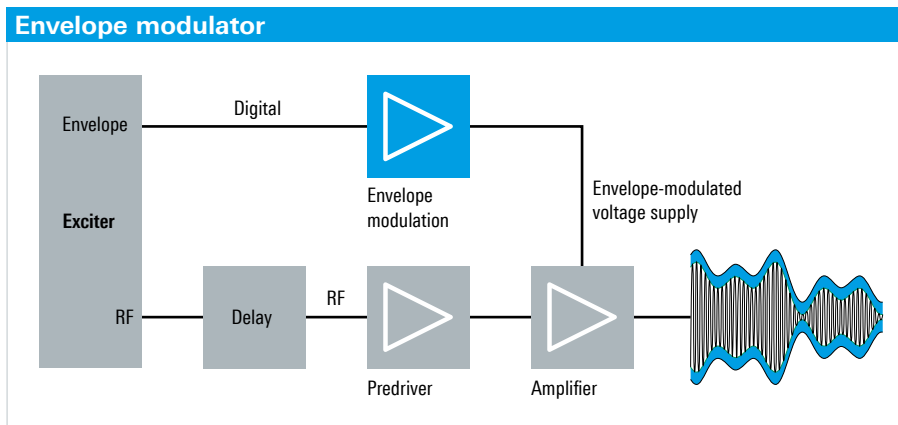

Fig. 2: Envelope modulation: The supply voltage to the RF power transistors is modulated with the envelope of the RF signal.

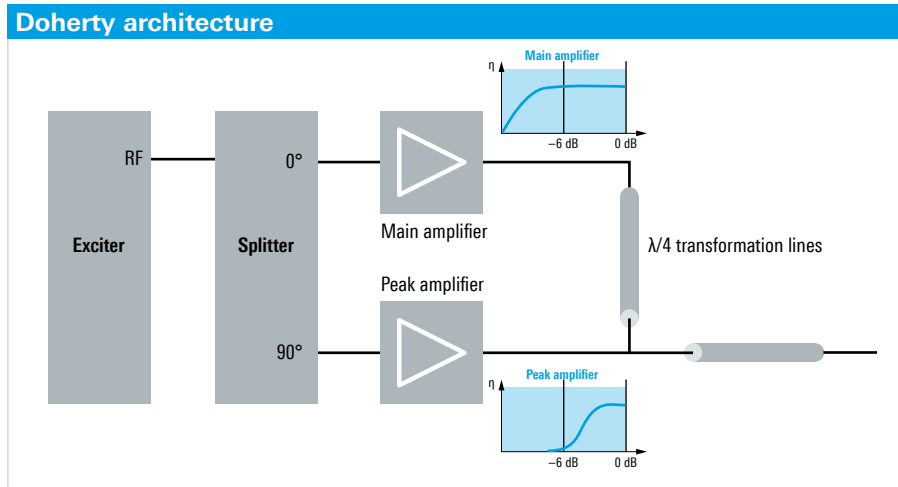

Fig. 3: The Doherty architecture splits the input signal into two paths.

The bias behavior of the transistors is another disadvantage. Since the supply voltage is not constant, the biasing will fluctuate, especially at low supply voltages (variation in gain factor and linearity properties). The benefit of envelope modulation is related to the broadband nature of RF amplifiers.

Due to lower MTBF as well as long-term stability problems and high production costs, envelope modulation is not the preferred solution for Rohde&Schwarz high-power transmitters when using amplifiers with multiple output stage transistors connected in parallel. In addition to increased capital expenditure, the operating expenses are also higher due to the necessary maintenance and repair.

## Doherty amplifiers

The Doherty architecture was already patented in 1936. The method involves splitting the input signal into two paths: the main amplifier and the amplifier for peak signals (Fig. 3).

An amplifier achieves optimum efficiency when it is operated in compression. Since the load impedance is constant in class AB amplifiers, this occurs only in the (rare) case of peak modulation. The Doherty method uses load modulation. In case of a symmetrical Doherty amplifier (identical main and peak path), only the main amplifier operates when the modulation is low. The load impedance is chosen so that the main amplifier operates with high efficiency at low modulation and goes into compression already at a quarter of the output power, attaining maximum efficiency. If the input signal level increases further, the peak amplifier will also amplify the input signal and the load impedance of the main amplifier is dynamically reduced. Starting at this time (back-off point), the main amplifier always operates at maximum efficiency and can also output more power (up to the peak modulation as in class AB operation) due to the reduced load

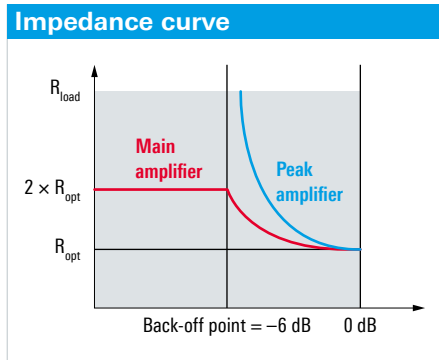

Fig. 4: Impedance curves of the main and peak amplifiers.

impedance. Fig. 4 shows the load impedance curves for the main and peak amplifiers, while Fig. 5 illustrates the efficiency curve. Although the transistor in the main amplifier delivers significantly higher AVG power than in the class AB amplifier, the junction temperature is much lower due to the good efficiency, resulting in higher MTBF. The disadvantage of the classic Doherty architecture is the very narrowband combiner based on  $\lambda/4$  line transformation for load modulation. The result are increased logistics costs due to the need for multiple narrowband amplifiers.

Compared to classic transmitter systems, the advantage of Doherty technology is that no changes are required in the architecture of the transmitter system. The only difference arises in the structure of the amplifier. Among all currently discussed solutions for improving the efficiency of power amplifiers for broadcast applications, the Doherty design represents the optimum solution for reconciling CAPEX versus OPEX:

- ▮ No increase in required components, meaning no reduction in MTBF
- ▮ Significantly higher efficiency
- ▮ Lower junction temperature for transistors, leading to higher MTBF
- ▮ Long-term stability

Fig. 5: Efficiency curve of a Doherty amplifier.

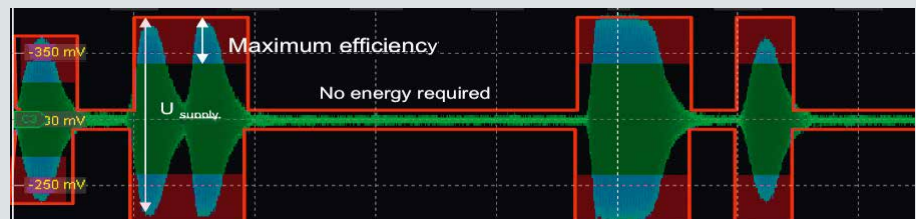
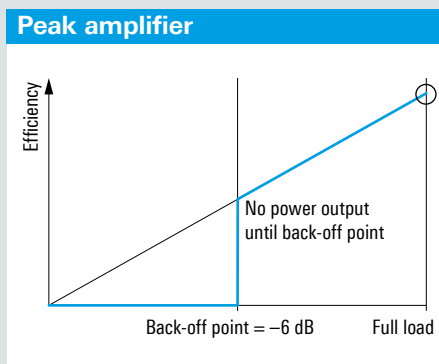
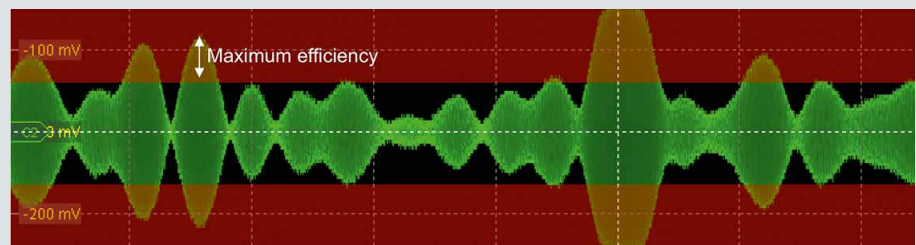
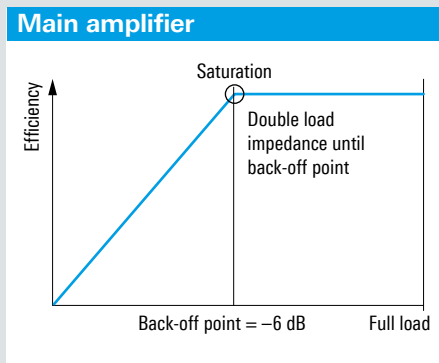



Fig. 6: R&S®PMU901 600 W amplifier.

### Multiband Doherty amplifiers from Rohde & Schwarz

High-power transmitters from Rohde & Schwarz are based on the Doherty concept while avoiding the disadvantages associated with narrowband combiners. Two transmitter systems of the first Doherty generation are currently in series production:

- R&S®TMU9 transmitter family (600 W to 3 kW AVG in one rack, Fig. 1), air-cooled with R&S®PMU901 600 W amplifiers (Fig. 6)
- R&S®THU9 transmitter family (1.2 kW to 14 kW AVG in one rack), liquid-cooled with R&S®PHU902 1200 W amplifiers

All amplifiers have a broadband design (470 MHz to 862 MHz) and a patented combiner with feedback function. The Doherty architecture is narrowband by nature. The patented Doherty Tunit frequency option in the R&S®PMU901 air-cooled 600 W amplifier along with the built-in combiner with feedback function turns a broadband class AB amplifier into a band-limited Doherty amplifier. The available Doherty range is replicated using the combiner with feedback function. As a result, only a few different Tunit variants are required to cover the entire band IV/V. The Tunit can be exchanged or replaced without any alignment and without opening the amplifier at the transmitter site. In an (n+1) transmitter configuration, it can be necessary to operate the standby transmitter in broadband mode. In this case, the amplifier can be switched from band-limited Doherty mode to broadband class AB mode.

The R&S®PHU902 liquid-cooled high-power amplifier can also be operated in two different modes: in band-limited, efficiency-optimized Doherty mode or in broadband mode. Band IV/V is divided into four Doherty ranges to optimize efficiency. Four suitable Doherty options come preinstalled in the amplifier and can be activated depending on the required operating frequency. If the operating frequency is outside the amplifier's selected Doherty range, the amplifier automatically switches to broadband mode. This allows unlimited usage, even in the standby transmitter in (n+1) systems.

The Doherty ranges are carefully coordinated to maintain efficiency as constant as possible across band IV/V. The efficiency of the R&S®PHU902 amplifier (referred to the input power from the grid) is 39 % to 40 % (typ.) for OFDM signals and 42 % to 43 % (typ.) for ATSC signals.

Thanks to Doherty technology, transmitter efficiency is typically increased by  $\geq 10\%$  compared to conventional class AB amplifier architecture, corresponding to energy savings of 40 %. The higher efficiency allows operators to save even more by redimensioning the cooling system.

Due to their advanced technology, it should come as no surprise that Rohde & Schwarz transmitters based on Doherty technology were deployed in TV projects around the globe shortly after their market launch.

Uwe Dalisda

# Compact BTS gateway for ISDB-T<sub>B</sub> networks

The R&S®AVG050 is a compact and versatile ISDB-T BTS gateway for ISDB-T<sub>B</sub>, a transmission standard mainly used in Latin America. The gateway is equipped with an integrated satellite receiver and remultiplexer, making it ideal for use between the local encoding/multiplexing center and the transmitter.

## Comprehensive functions

The R&S®AVG050 ISDB-T BTS gateway (Fig. 1) has an integrated satellite receiver and DVB-S / DVB-S2 demodulator for receiving and processing national programs. Local content is usually fed in in standard-definition (SD) format. It is generated in a local headend and can be fed to the R&S®AVG050 as a transport stream over IP or ASI (Fig. 2). The gateway multiplexes the satellite-fed or locally fed content to a new transport stream and generates a broadcast transport stream (BTS) with the appropriate modulation parameters for the transmitter and the corresponding signaling information (PSI/SI) for the receivers.

The gateway has two common interface (CI) slots for conditional access modules (CAM) used to decrypt the DVB-S / DVB-S2 signals and therefore supports two different encryption methods at the same time. The R&S®AVG050 can also decrypt two signals scrambled according to the basic interoperable scrambling system (BISS) standard (BISS-1 and BISS-E).

A clearly organized, intuitive user interface is provided for configuration and monitoring. All automatic monitoring commands and key device settings can also be remotely executed via an SNMP interface.

## The R&S®AVG050 is also available as a pure satellite receiver

More and more infrastructures for transmitter networks and closed user groups such as business, hospital and hotel TV use IP-based solutions. Since these applications often do not require any decoding in the receiver, the R&S®AVG050 is also available as a pure demodulator without remultiplexing function. The R&S®AVG050 DVB satellite receiver model features two integrated DVB-S / DVB-S2 demodulators for receiving two transponders. A built-in BISS descrambler and two CI slots are provided for DVB-compatible decryption. After the incoming transport streams are decrypted, the DVB satellite receiver outputs them as IP or ASI signals.

Key features of the R&S®AVG050 DVB satellite receiver:

- Two DVB-S / DVB-S2 receivers with two CI slots
- Integrated BISS descrambling
- ASI and IP outputs
- Configuration and monitoring via SNMP
- Compact: only one height unit and ½ rack width

Fig. 1: The R&S®AVG050 ISDB-T BTS gateway multiplexes satellite transport streams and locally fed components to a new BTS.





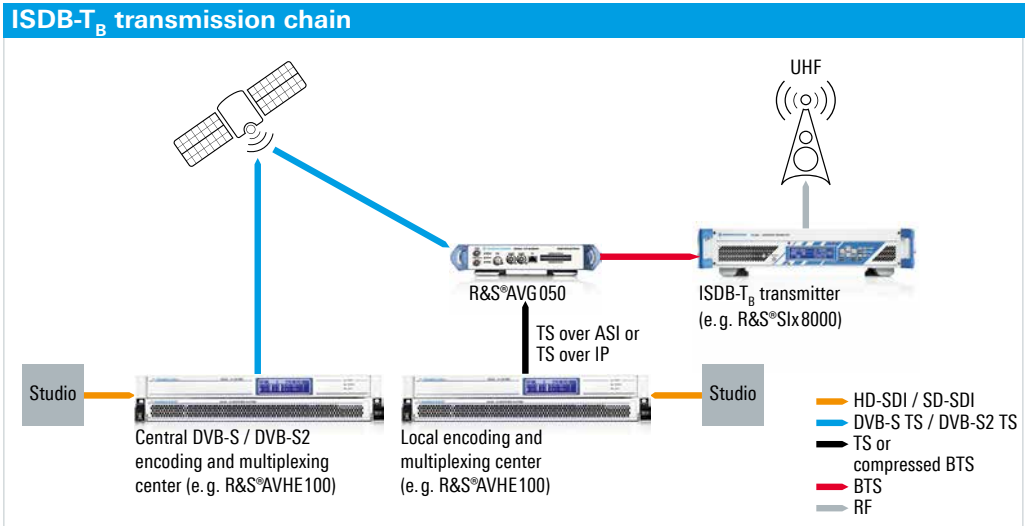

Fig. 2: The central encoding and multiplexing center transmits the transport streams via satellite to the different transmitter sites. The R&S®AVG050 uses the satellite-fed and local programs to generate a new BTS for the transmitter.

### Summary

The R&S®AVG050 ISDB-T BTS gateway expands the product range for the Latin American market. In addition to transmitters and T&M solutions for ISDB-T<sub>B</sub>, the portfolio now includes the appropriate BTS gateway with integrated satellite receiver. The gateway is very compact, yet offers

comprehensive functions. Since it is only half the width of a 19" rack, two gateways can be placed next to each other in one height unit. In addition to space savings, it also offers the advantage of low power consumption.

Claudia Görig; Denis Hagemeyer

### Typical topology of ISDB-T<sub>B</sub> transmitter networks

The ISDB-T<sub>B</sub> transmission standard for digital broadcasting is a modification of the Japanese ISDB-T standard. It mainly differs from ISDB-T by using H.264/MPEG-4 AVC instead of MPEG-2 for video coding and MPEG-4 AAC instead of MPEG-2 AAC for audio coding. It is also used to transmit data services.

In ISDB-T<sub>B</sub> networks, national programs are usually transmitted to the transmitter site via satellite (DVB-S / DVB-S2). The distances are often so large that the transmission of data streams via optical fiber or microwave links is too costly, and some countries do not have the necessary infrastructure.

Since satellite-fed signals can be received nationwide using common set-top boxes, the programs are transmitted in encrypted form and only available to pay TV end users in the respective transmitter region. These satellite streams have to be decrypted at the transmitter site and subsequently remultiplexed to a new BTS. It is possible to add regional programs during this process. CAMs inserted in the satellite receiver's CI slots are usually used for the decryption. After decryption, the newly generated BTS is fed to the transmitter.

Unlike DVB-S / DVB-S2 transport streams, the newly generated BTS has a fixed data rate of 32.508 Mbit/s and a defined frame structure for transmitting up to three layers (A, B, C) with different modulation and error protection. Depending on the selected transmission parameters, the BTS contains 30 % to 50 % null packets as placeholders. In addition to SD and HD programs for stationary reception, the BTS can contain 1seg programs for mobile reception at low data rates. It is common practice in Latin America to transmit three programs per ISDB-T<sub>B</sub> frequency: one HD program, 1seg program with the same content and an additional SD program.

# HDMI 2.0 signal generator for testing 4k consumer electronics equipment

A new signal generator module for the R&S®VTC / VTE / VTS video testers can now generate signals for testing next-generation 4k display devices. It offers four parallel 4k UltraHD HDMI outputs and supports the 3G mode specified in the HDMI 2.0 standard with 4:2:0 pixel encoding as well as the required signaling.

**HDMI Licensing, LLC has released a new version of its interface standard: HDMI 2.0. Rohde & Schwarz played an active role in developing the corresponding test standards. This makes the company one of the first T&M equipment manufacturers to offer an HDMI 2.0 3G mode update for its R&S®VTC, R&S®VTE and R&S®VTS video testers. These video testers cover virtually all of the tests that have to be performed on A/V components in the consumer sector. For more information, visit [www.the-av-experts.com](http://www.the-av-experts.com)**

## Test signals in line with CEA-861-F and VESA

With their combined generator and analyzer functions, the R&S®VTC / VTE / VTS video testers can be flexibly used to test a wide range of A/V interfaces. For example, the [R&S®VT-B2361 HDMI RX 300 MHz](#) analyzer module is already available for source tests in line with HDMI 2.0.

An appropriate generator module is now also available for testing HDMI sinks such as TV sets, projectors and monitors. The new [R&S®VT-B360 HDMI TX 300 MHz signal generator module](#) (Fig. 1) offers a range of static test patterns such as color bars, primary colors, greyscales, monoscopes, ramps, etc. that can be output in all CEA-861-F and VESA video formats up to 4k (3G mode) (Figs. 2 and 4). The test signal content can be adjusted by changing the pixel encoding, DVI mode, 3D mode, level, bit depth and pixel shift. There is also a PCM tone generator for generating audio test signals with different sampling rates and audio levels for up to eight channels.

The [R&S®VT-K361 HDMI moving pictures software option](#) provides an extra 8 Gbyte of RAM to play uncompressed moving picture sequences in all supported resolutions (Fig. 5). With UltraHD resolutions of 4096 × 2160 pixels or 3840 × 2160 pixels, playout of up to 20 seconds is possible, depending on refresh rate and coding. Rounding out the range of functions is a signal library with nature scenes and test patterns that permit lip sync and EMC measurements, for example. The [AVG pattern import software](#) allows conversion of pictures or picture sequences into customer-specific test signals (Fig. 6).

The [R&S®VT-K362 HDMI user defined option](#) can be used to generate user-specific signals (Fig. 3). This option allows users to configure nonstandard resolutions and set InfoFrames as required (AVI, audio, SPD, VSI).

## DDC, CEC and HEAC testing

The HDCP encryption function can be activated and tested at all inputs. Supported TV resolutions and formats can be output and saved using the EDID reader. The saved EDID data can either be analyzed in plain text or loaded as binary file into the R&S®VT-B2360 / -B2361 HDMI analyzer modules.

<b>ARC</b>	audio return channel
<b>CEC</b>	consumer electronics control
<b>CTS</b>	compliance test specification
<b>DDC</b>	display data channel
<b>EDID</b>	extended display identification data
<b>HDCP</b>	high-definition content protection
<b>HEAC</b>	HDMI Ethernet audio channel
<b>HEC</b>	HDMI Ethernet channel

Fig. 1: The R&S®VT-B360 HDMI TX 300 MHz signal generator module permits HDMI interface testing of 4k UltraHD consumer electronics equipment.





Fig. 2: Signal menu for selecting test patterns and signal timing.



Fig. 4: The R&S®VT-B360 base module offers a range of static test patterns in the relevant resolutions.



Fig. 3: The R&S®VT-K362 HDMI user defined option permits configuration of user-specific InfoFrame contents and other settings.

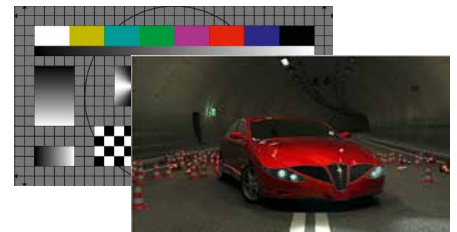

Fig. 5: The R&S®VT-K361 HDMI moving pictures option provides 2D and 3D moving picture sequences at resolutions of up to 4k.



Fig. 6: The AVG pattern import software tool permits users to generate their own test patterns and test sequences.

The R&S®VT-K2366 CEC tracer option is used to test consumer electronics equipment to ensure correct processing of the CEC function, which is part of the HDMI standard. The ARC and HEC can also be tested using the module's basic functions.

### Protocol test in line with CTS

To ensure interoperability, specific test signals described in official specifications are provided in addition to the generator module characteristics presented above, which are frequently used for functional tests. The R&S®VT-K365 HDMI CTS sink test software option contains protocol tests in line with HDMI CTS 1.4b and 2.0 (see product brochure for details).

### Summary

With the new HDMI generator module and expanded functional range of the HDMI analysis modules, the family of video testers offers a unique range of functions for testing next-generation 4k UltraHD consumer electronics equipment in development, quality assurance and manufacturing.

Harald Gsödl

# 10 000 ATC radios in 54 countries: R&S®Series 4200

February 2006: Rohde & Schwarz presented its new radio for civil and military air traffic control at ATC Global in Maastricht. Seven years later, R&S®Series 4200 radios are being used by air navigation service providers (ANSP) in 54 countries. The 10 000th unit is coming off the production line. A reason to celebrate.

## Flying high – ATC with Rohde & Schwarz

Numerous air navigation service providers worldwide have been relying on Rohde & Schwarz radios and service for decades. The R&S®Series 4200 radios for air traffic control are part of this success story. (Figs. 1 and 2). They cover practically all ATC radiocommunications requirements with different models and different frequency ranges. They are continuously being enhanced to keep up with technological progress. For example, over the years, they were equipped with additional interfaces to the voice communications systems (VCS) via which air traffic controllers communicate with pilots. Today, they support both voice communications and the controller-pilot data link communications (CPDLC) service, which

is currently being introduced in Europe and the USA. Thanks to its consistent enhancement, the R&S®Series 4200 has been able to maintain its market position and is currently being used in 54 countries.

And the demand is unbroken. In August 2011, Rohde & Schwarz won the tender for a contract with DFS Deutsche Flugsicherung GmbH (Germany's national ANSP) for their project RASUM 8.33 – radio site upgrade and modernization with 8.33 kHz conversion (see box). In addition to delivering R&S®Series 4200 radios, the contract included the technical and organizational planning and coordination plus responsibility for the overall integration of the radio

Fig. 1: The R&S®XU 4200 VHF transceiver from the R&S®Series 4200 radio family.



Fig. 2: The photo shows a radio of the R&S®Series 4200 and one of its predecessors from the 1970s. It can be seen how immensely the technical advances in the last decades have contributed to minimizing radio size. The state-of-the-art R&S®Series 4200 radios are not only space-saving. They also significantly reduce a radio site's power consumption.



Photo: Hans-Jürgen Koch, DFS

sites. Within the framework of contract performance, the 10000th unit came off the production line of the Rohde&Schwarz Vimperk plant in February 2013. This was an occasion for DFS and Rohde&Schwarz to celebrate. During the celebration, the 10000th ATC radio was ceremoniously presented to Hermann Mehringer, responsible for radiocommunications at DFS, and Thomas Dehnhardt, RASUM project manager, at the DFS company headquarters in Langen near Frankfurt/Main (Fig. 3). The radio is being used at the transmitter site on Feldberg mountain.

In the meantime, approximately 1250 R&S®Series 4200 radios are in use by DFS. Has there ever been better proof of customer satisfaction?

Bernhard Maier



Photo: Hans-Jürgen Koch, DFS

Fig. 3: The teams of DFS and Rohde & Schwarz during the ceremonial presentation of the 10000th radio.

### RASUM 8.33 project of DFS (Germany's national ANSP)

DFS operates approximately 160 radio sites in Germany. EU Regulation 1079/2012 obliges all ANSPs in Europe to convert their radio systems to support the new 8.33 kHz

channel spacing by 2018. This measure triples the number of available ATC radio channels in the limited spectrum from 118 MHz to 137 MHz. Under the EU regulation, a large number of old radios that do not support the 8.33 kHz channel spacing must be

replaced. While complying with this obligation, DFS took the opportunity to modernize many of its radio sites. DFS not only exchanged radios, but also set up new radio sites, replaced antennas, renovated buildings and updated technical infrastructures.

## Rohde & Schwarz opens new office complex



Munich headquarters expanded: Rohde & Schwarz has invested around EUR 60 million in a new office complex. A total of 12,000 square meters of modern office and lab space were built. Approximately 570 employees moved into the building in July 2013.

## Innovative components and technologies at in-house trade fair

Around 90 key suppliers exhibited their latest products at the May 2013 InnoComp, the Rohde & Schwarz in-house trade fair. Especially the company's developers were called on to inform themselves about the latest technologies. Consequently, a major focus of the fair was on the transfer of expertise. Short innovation cycles and continuous shifts of the market mean companies must respond ever more quickly to new developments. The goal of the InnoComp fair is to intensify cooperation between Rohde & Schwarz and its strategic suppliers and to utilize this close cooperation to continuously expand its innovative capacity.

## New Teisnach production hall officially opened

In July 2013, Rohde & Schwarz Teisnach celebrated the opening of the new production hall together with 1400 guests. The Prime Minister of the State of Bavaria, Horst Seehofer, was the guest of honor. During his speech he emphasized that the

Munich-based company is "one of Bavaria's flagships". The recent investment of more than EUR 10 million bolstered the Teisnach site yet again. The total production space was increased to more than 62,000 square meters.



From left: Plant Manager Johann Kraus, Executive Vice President Dr. Dirk-Eric Loebermann (head of the production and materials management division), Bavaria's Prime Minister Horst Seehofer, and President and CEO Manfred Fleischmann.



The InnoComp, which has been held since 2001 is very popular with the exhibitors, who are mostly longtime Rohde & Schwarz partners.

## Royal Malaysian Navy highly satisfied with Rohde & Schwarz



Alan Seah, Managing Director of Rohde & Schwarz Malaysia, with Royal Malaysian Navy Chief, Admiral Tan Sri Dato' Seri Abdul Aziz bin Hj. Jaafar.

Rohde & Schwarz Malaysia Sdn Bhd has received an excellent performance evaluation for its management of a service contract for the Royal Malaysian Navy (RMN). RMN contract supervisors made their evaluation on the maintenance contract for the RMN's secure communications program. Contract responsibilities include scheduled maintenance work and repair of Rohde & Schwarz systems installed aboard ships, submarines, helicopters, off-shore stations, naval bases, and post-sale logistics support. The three-year contract began on January 4, 2011, and will end on January 4, 2014. All projects defined within the contract were successfully completed within the stipulated time frame.



An integrated communications system from Rohde & Schwarz is installed aboard this Royal Malaysian Navy (RMN) Kedah class patrol vessel.

Logistics support was not limited to simply supplying spare parts. It also included technical advice and improvements or modifications to increase the efficiency of the equipment and systems that are in service. Rohde & Schwarz staff gave credit for the smooth execution of the contract to the close cooperation between the company and the RMN units involved. The high level of commitment provided by Rohde & Schwarz was another key factor for RMN because it helps maintain a high level of equipment operation and ensure failsafe performance.

## Successful workshop in Montenegro

In June 2013, the Radiomonitoring and Radiolocation Division had the opportunity to present two innovative solutions during a two-day workshop in Budva, Montenegro: the R&S®ARGUS monitoring software, version 6, and the R&S®DDF007 portable direction finder with the R&S®Mobile Locator software. Customers from 14 European countries attended the event. The highlight of the workshop was a live demonstration of the Mobile Locator software. Two vehicles were equipped with a portable direction finding system. The objective was to demonstrate how reliable signal location with a direction finding system is.

## SK Telecom and Rohde & Schwarz form cooperation



Rohde & Schwarz President and COO Christian Leicher and Choi Jin-sung, Head of ICT R&D at SK Telecom, are looking forward to working together.

In August 2013, SK Telecom, Korea's largest telecommunications company, and Rohde & Schwarz signed a memorandum of understanding (MoU). The companies plan to jointly develop test concepts and methods to verify active antennas for next-generation base stations. A test environment for verifying antenna system performance will be set up. Rohde & Schwarz supplies SK Telecom with R&S®SMW200A vector signal generators and R&S®SGS 100A RF sources as well as the R&S®TSMW universal radio network analyzer.



The Montenegro control and monitoring center (GKMC) is equipped with a Rohde & Schwarz monitoring system.

# Your question: EMI debugging with oscilloscopes?

## Our answer:

**Yes, you can! With digital oscilloscopes from the EMC expert.**

The R&S®RTO digital oscilloscope is a valuable tool for analyzing EMI problems. Using near-field probes, electronic design engineers can quickly understand unwanted emissions and identify their causes.

## Your advantages at a glance:

- High-speed, easy-to-use FFT
- Wide dynamic range and high sensitivity of 1 mV/div
- Color-coded display of the frequency of occurrence of spectral components to reveal intermittent signals
- Correlated time-frequency analysis with gated FFT
- Frequency mask for capturing sporadic events

## See for yourself:

[www.scope-of-the-art.com/ad/emi](http://www.scope-of-the-art.com/ad/emi)

Save up to **40%**  
on a new scope now!

Special trade-in Program  
available until June 2014:  
[www.scope-of-the-art.com/ad/trade-in](http://www.scope-of-the-art.com/ad/trade-in)

